

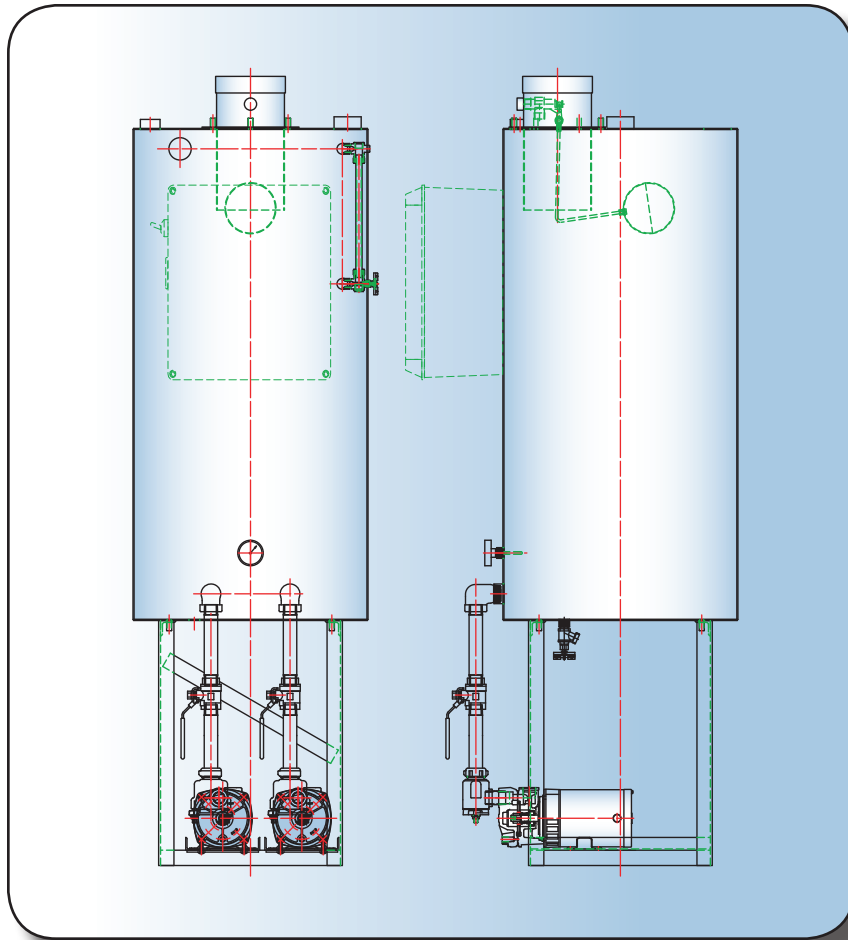

Boiler Feedwater Systems General Installation, Operation, & Service Instructions



INSTALLER: PLEASE LEAVE THIS MANUAL FOR THE OWNER'S USE.

⚠ WARNING

SAFETY INSTRUCTIONS

This safety alert symbol will be used in this manual and on the unit safety instruction decals to draw attention to safety related instructions. When used, the safety alert symbol means **ATTENTION! BECOME ALERT! YOUR SAFETY IS INVOLVED!** FAILURE TO FOLLOW THESE INSTRUCTIONS MAY RESULT IN A SAFETY HAZARD

⚠ WARNING

DO NOT PRESSURIZE TANK
DO NOT RESTRICT VENT
DO NOT PLUG OVERFLOW
OPEN INLET VALVES SLOWLY
DO NOT USE AS A FLASH TANK

FAILURE TO FOLLOW INSTRUCTIONS COULD RESULT IN SERIOUS INJURY OR DEATH

⚠ CAUTION

DO NOT RUN PUMP DRY, SEAL DAMAGE MAY OCCUR.

FAILURE TO FOLLOW INSTRUCTIONS COULD RESULT IN INJURY OR PROPERTY DAMAGE.



432 EAST SOUTH STREET
PLANO, IL 60545
WWW.FABTEKAERO.COM
SM@FabtekAero.com



Introduction

The life of a boiler feed system, and its pump can be extended considerably by proper installation, operation, and maintenance described in this manual.

DESCRIPTION

PRELIMINARY INSPECTION

Assure that there is no shipping damage.

HANDLING

Use care in installing unit. Avoid Jarring.

Typical Installation

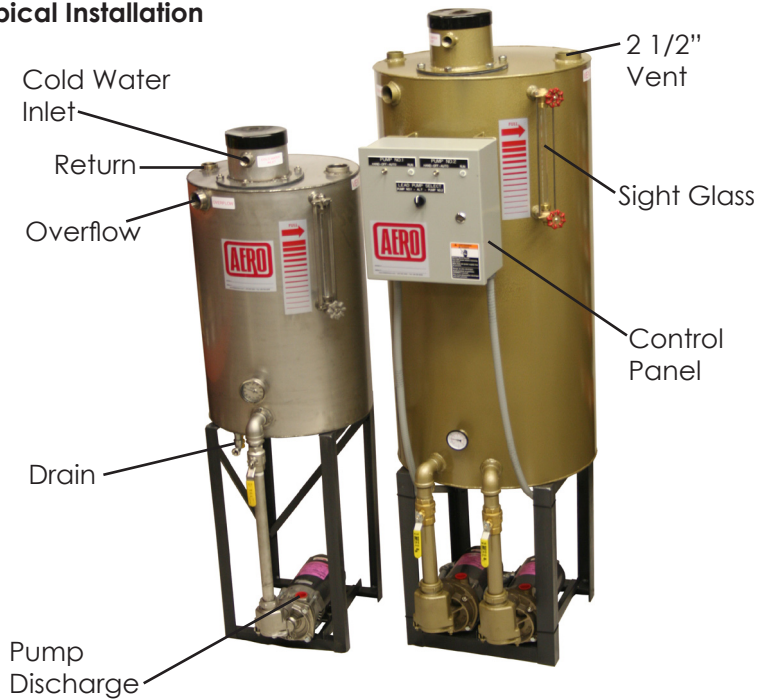

WARNING

EXPLOSIBLE

Do not pressurize receiver. Isolate

receiver during leak test. Do not plug overflow. Do not restrict vent opening to atmosphere. Open valves slowly. Failure to follow these instructions could result in serious injury or death.



CAUTION

NOT A CHEMICAL PUMP

Inject boiler feed com-

pounds from chemical feed tank into boiler feed piping - never into condensate tank. Failure to follow these instructions could result in injury or property damage.



WARNING

HIGH VOLTAGE ELECTRICITY

Disconnect and lock out power before connecting or servicing unit. Failure to follow these instructions could result in serious injury or death.

PIPING (General)

Pipe the unit per P & ID and isometrics.

PIPING (Returns)

Gravity return lines from system should be properly pitched down to unit inlet. Returns must also be trapped to prevent steam entry into the unit. An inlet basket strainer is recommended.

Bypass piping to a drain is recommended per the piping diagram.

PIPING (Vent)

Install a vent pipe to atmosphere. Pipe to be size of vent port on unit. Do not restrict or reduce vent opening or exceed 20 inch vertical height unless an overflow connection is provided.

PIPING (Overflow)

Pipe over-flow port to a floor drain. Take precaution and use an overflow loop when condensate temp exceeds 200°F (93°C).

Piping (Pumps)

The use of pipe hangers and support blocks near the pump discharge will prevent excessive

strain on the pump casing and the pipe joints. Discharge piping should be as direct as possible to keep friction losses at a minimum. Long radius elbows should be used in place of standard elbows where possible. Avoid using any elbows directly at the pump discharge. A check valve and a gate valve are recommended in the discharge piping.

FLOAT SWITCHES & MECHANICAL ALTERNATORS

Floats are locked in place to prevent damage during shipment.

Remove shipping locks. Check factory settings. Floats and mechanical alternators are adjustable for various levels of operation.

ELECTRICAL WIRING & CONTROLS

Connect power wiring per NEC. Check settings of adjustable motor overloads. Typically they are set at .5 to 1.0 amp greater than maximum motor draw. All single phase motors have internal thermal protection.

Three phase motors must use starters with properly sized overload relays. Overload relays furnished are designed for manual reset.

Principles of Operation

In a boiler feed system, a pump supplies make-up water to the boiler as the boiler water is turned into steam. Steam boilers operate under pressure, so the pump must develop enough pressure to overcome the boiler pressure as well as losses due to friction from piping and check valves. Regenerative turbine pumps are desirable for on/off water supply, as opposed to continuous feed make-up. A centrifugal pump used in conjunction with a modulating valve is the



432 EAST SOUTH STREET
PLANO, IL 60545
WWW.FABTEKAERO.COM
SM@FabtekAero.com



typical arrangement utilized when continuous operation is required.

Installation Location

A boiler feed system should be located as close to the boiler as possible, so the discharge piping has minimum number of elbows and fittings.

Boiler feed systems should be located in a clean, open area with easy pump accessibility for maintenance, inspection, and repair. It should also be located for ease of movement by a crane, hoist, or forklift. Proper Drainage should also be considered prior to installation.

Provisions should be made for wiring of electrical components. A line switch and overload protection should be installed near the boiler feed system if possible. All electrical connections should be made to eliminate the possibility of moisture entering.

The foundation for a boiler feed system should be sufficiently rigid to absorb any vibration encountered during operation, and strong enough to support the feed water tank when filled to capacity. The frame of the boiler feed system should be firmly bolted to the foundation.

Installation

The standard boiler feed system includes a tank supported by an angle-iron frame and a base, containing a pump and motor assembly. The system as received from the factory is ready for installation.

It is extremely important to ensure the system is level before put into operation. A level and shims can be used to accomplish this.

NPSH Requirements

Temperatures may affect pump performance above 190°F in a boiler feed tank. At this point, a pump could cavitate, causing a loss of performance that will lead to pump failure.

Priming the Pump

Always fill the tank and pump before start up. All air must be expelled from the suction piping and pump casing to prevent pump seal failure.

Boiler feed start-up

Check to ensure that all electrical connections are properly installed.

Check that all valves are in proper position for correct operation.

Check that all pump, motor, and base plate bolts are firmly tightened.

PUTTING THE UNIT INTO SERVICE

1. Assure that the unit is piped in accordance with instructions in this manual.
2. Isolate tank before performing any system leak test. Do not pressurize the tank as part of the leak test. Failure to do this can result in serious injury or death.
3. Wire unit per National Electrical Code. See representative wiring diagrams.
4. Install drain plugs if necessary.
5. Fill receiver half full of water to prime pump(s) and prevent possible damage to pump seals. Avoid freezing conditions after unit receiver has been filled.



DO NOT RUN DRY. SEAL DAMAGE MAY OCCUR.

Inspect pump seal regularly for leaks. Replace as required. Failure to follow these instructions could result in injury or property damage.

6. Check for proper rotation of all three phase motors. Rotation must be clockwise looking down on the motor as indicated by directional arrow on pump casting. If pump runs backwards, interchange two wires (3 phase only).



DO NOT REVERSE

Reverse operation can

cause extensive damage to pumps. Jog the motor to test for direction of rotation. Failure to follow these instructions could result in injury or property damage.

7. Assure all shipping locks have been removed from all float switches.

8. If possible, observe operation thru several cycles.



SUBSEQUENT DAMAGE

A unit showing symptoms

of possible problems (overflow, noise, leaks, vibrations, continual operation, etc.) must be corrected immediately. Failure to follow these instructions may result in full liability for subsequent injury or property damage.

OPERATION AND MAINTENANCE

Operators must be familiar with all sections of this manual to understand the operation of the unit.

Hot water, steam and electricity can be hazardous. Check motor nameplate for any lubrication requirements.

Pumps require no lubrication.

NOTICE / AUTO RESTART

Overload thermal relays in starters must be reset manually.

A properly installed unit should function unattended for long periods of time. Periodic checks to assure proper operations are highly recommended. Refer to trouble shooting section when necessary.

A variety of control options are available and are furnished in accordance with user specifications. Refer to wiring diagrams (when furnished) to determine control switch settings.

The inlet strainer (when furnished) is intended to protect the pump and system. Periodic cleaning should be included in the maintenance schedule. Check frequently in new systems.



432 EAST SOUTH STREET
PLANO, IL 60545
WWW.FABTEKAERO.COM
SM@FabtekAero.com



MAINTENANCE

Clean the pump suction strainer screen every 6 months.

Clean out sediment from the bottom of the tank every few years as required.

Make sure the make-up valve shuts off tightly, (no drips) when the tank approaches the desired full level.

If the tank overflows due to condensate return, adjust the float valve linkage to lower the make-up water level.

Check float valve linkages at both pivot points to be sure connections are tight.

Make sure there is no stray voltage between the tank and ground. As little as 300 millivolts can cause severe electrolysis in the receiver.

See Pump Instruction Manuals for Pump Details TROUBLE SHOOTING PROCEDURE

All units are thoroughly tested at the factory before shipment.

They should operate satisfactorily without further adjustment if properly installed and providing they have not been damaged by rough handling in transit. If system or unit performance is

not satisfactory, refer to the following check list.

Pump Will Not Start

1. The power supply has been interrupted, disconnect switch is open, or selector switch is improperly positioned.
2. Incorrect voltage for motor. Check voltage and wiring with motor characteristics.
3. Incorrect starter coil for power supply.
4. The overload relays and the starter have tripped out and must be reset. Ambient temperature may be too high.
5. Check pump controls or other controls for proper operation.
6. Wiring to control cabinet is incorrect or connections are loose.
7. The strainer is dirty thus retarding flow. Clean periodically.

Pump Runs Continuously

1. Pump is running backward. Rotation of three phase motors may be corrected by interchanging any two of the three wires. Rotation should be clockwise looking down on motor.
2. Steam traps are blowing through causing condensate to return at excessive temperatures. This may reduce the capacity of pump below its rating, depending on the unit and type of pump furnished. Traps should be repaired or replaced.
3. The total required pressure at the pump discharge is greater than the pressure for which the pump was designed. Check the total pressure which includes atmospheric pressure, the friction head and the static head.
4. A valve in the discharge line is closed or throttled too tightly. Check valve is installed backwards.
5. The impeller eye is clogged.
6. Pump is too small for system.

Condensate Pump is Noisy

1. Excessive condensate temperature. Correct system conditions.
2. Magnetic hum or bearing noise in motor. Consult motor manufacturer's authorized service station nearest unit location.

3. Starter chatters. Trouble is caused by low line voltage, poor connections, defective starter coil, or burned contacts.
4. Pump is running backward.

The System is Noisy

1. Banging in steam mains is usually caused by steam "imploding" in condensate lying in low points in lines. These problems can be eliminated by dripping low points, properly supporting the pipe, or by increasing the pitch of the lines.
2. Improper dripping of the steam mains and risers; where there is a rise in the steam main, or where it branches off into a riser, a drip trap must be installed in the drain line.
3. The piping is too small to drain properly.
4. A defective trap is holding condensate in steam supply line.



432 EAST SOUTH STREET
PLANO, IL 60545
WWW.FABTEKAERO.COM
SM@FabtekAero.com