

C4 • C5 • C6 SERIES

Pump Manual

HORIZONTAL CLOSE COUPLED

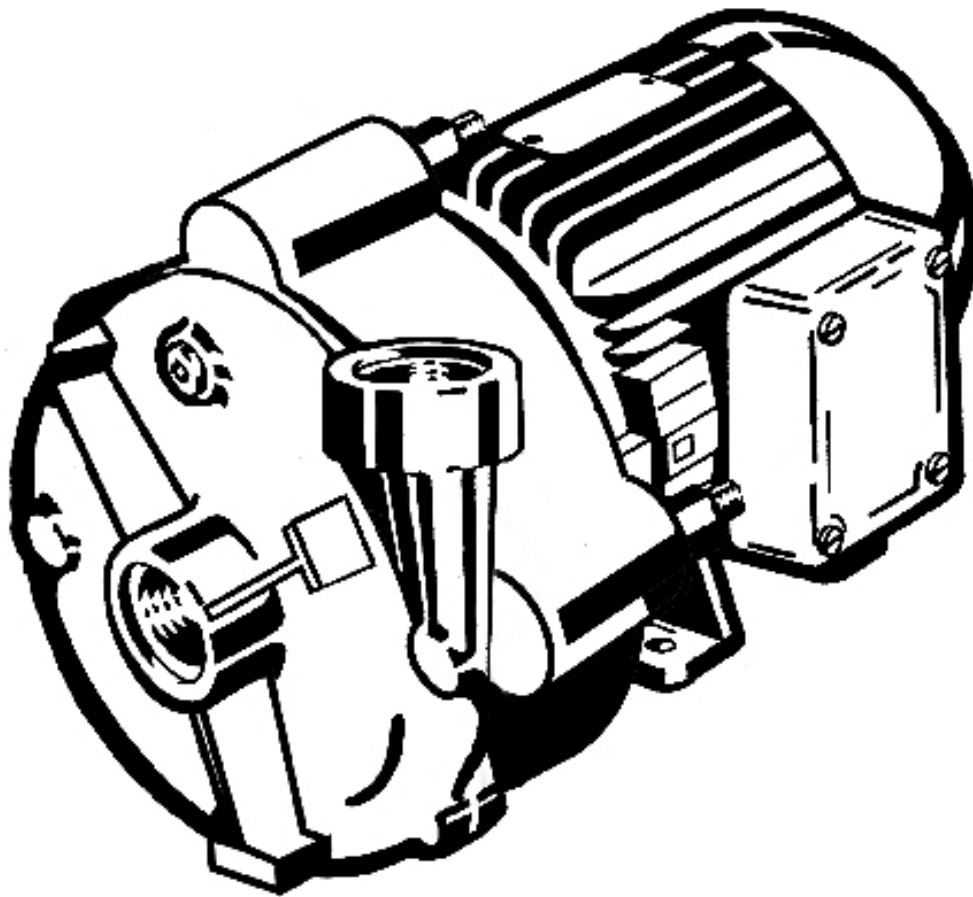

432 EAST SOUTH STREET
PLANO, IL 60545
WWW.FABTEKAERO.COM
Sales@FabtekAero.com

1. General Instructions

CENTRIFUGAL PUMPS

- A. Inspection of Equipment
- B. Storage
- C. Placing Stored Pumps Into Service
- D. Recommended Spare Parts

When properly installed and given reasonable care and maintenance, centrifugal pumps should operate satisfactorily for many years. The C Series pumps use tight running clearances to build pressure. Abrasive particles in high enough concentrations, can eventually open up the close clearances between the impeller and the casing, thus reducing pressure output. To avoid this, careful selection and use of a low resistance suction strainer should be considered. For critical services it is recommended that you keep an identical pump for stand-by use.

1A Inspection of Equipment

Immediately upon receipt of the shipment, inspect the equipment for damage or missing components. Check the shipping manifest and report any damage or shortage to the Transportation Company's local agent.

Put the instructions that came with the shipment in a safe place where they will be available to those who will be using them for installation and service.

1B Storage

If the pump is to be stored before use, it should be inspected as described in 1A, crated and stored in a dry location. Standard shipping containers are not suitable for outdoor storage. In some areas, it may be necessary to cover the pump's exterior surface with oil or other rust inhibiting coating.

1C Application Considerations

1C1 Electrical Wiring

All electrical equipment and wiring should conform to Local and National Electrical Codes. Use the motor manufacturer's instructions for connecting the motor. Note the correct rotation and wiring diagrams on the assembly. Make sure the motor rotation and speed matches that required for the pump.

1C2 Construction Materials

While it is reasonable to assume that good judgement has been used in selecting all the materials in the pump for compatibility with process fluids, actual conditions sometimes vary from original expectations. Also, typical material selection charts do not consider all the temperature, pressure, and fluid variables. The customer's engineer should be consulted for final judgement on the best materials for critical process applications.

1C3 Valves

If a shutoff valve is necessary in the suction line, use a gate, ball, butterfly, or other full port valve. Globe or other flow restricting valves, can in some cases, reduce pump flow or increase chances of cavitation.

A swing check valve in the suction line is recommended even when the pump inlet is only slightly higher than the fluid source to aid in priming. It should be the same size as the pump inlet or sized based on reasonable fluid friction losses.

A foot valve is recommended when lifting fluid from a sump. This will save wear and tear on any pump, even those equipped with self priming equipment.

A low resistance Suction Strainer is recommended immediately ahead of the pump on any newly constructed system. This is advisable due to the probability that foreign material large enough to damage pump clearances may remain, even though the piping has been flushed.

Valves in the outlet piping of a centrifugal pump should be closed, or nearly closed, when the pump is started. This will reduce the start-up load on the pump and motor. **Never start the pump with the discharge valve fully open, unless system friction losses are substantial enough to prevent the pump from operating at "run out," otherwise cavitation or motor overload may occur.**

Inlet valving should be fully open when starting any pumping system. Without some fluid in the pump at startup, the unit can gall and lock up the impeller. Always fill the pump and vent it of air for best pump life. **Violent pump failure will result from continued operation with the inlet valve closed.**

1C4 NPSH (Net Positive Suction Head)

The NPSH required varies with every size and capacity of pump. The NPSH required by your unit can be obtained from the performance curves or from your Fabtek Aero representative.

If the NPSH available is not equal to or greater than that required by the pump, it must be increased or a different pump selected. The usual method for increasing NPSH is to raise the static head on the pump inlet, (H_s).

By definition, NPSH means: "Net Positive Suction Head" above the vapor pressure of the pumped liquid, available at the centerline of the pump. It should always be given in feet of pumped liquid. The NPSH is actually a measurement of the amount of energy available in the pumped liquid to produce the required absolute entrance velocity in the pump. If a pump requires more energy (or NPSH) than is available at a given capacity, the pressure at the inlet will fall below the vapor pressure of the pumped liquid and fluid vaporization and loss of performance will result.

P_s = Pressure in the suction vessel in PSIA.

P_{vp} = Vapor pressure of the pumped fluid in PSIA.

H_s = Static height of the pumped fluid above (+) or below (-) the centerline of the pump.

H_f = All friction losses from the vessel to the pump.

$$NPSH = 2.31 \left(\frac{P_s - P_{vp}}{SP\ GR.} \right) + H_s - H_f$$

For boiling liquids, P_s and P_{vp} are equal. This item then becomes zero and can be omitted from the equation.

1C5 Noise

Motors, bearings, and other rotating components add to noise, which sometimes create objectionable harmonics.

Careful pump installation can contribute to noise reduction. Proper alignment of the pump and driver is essential. Adequate supports for the inlet and discharge piping is equally important. A degree of noise reduction may be obtained when the pumping unit is supported free of building structures by the use of vibration isolators, flexible piping and conduit connections. To separate motor noise and vibration from the fluid and piping structure, using a flexible elastomer-coupled (long coupled) configuration is very desirable.

1C6 Freezing

When ambient temperatures drop below the freezing point of the fluid, consideration should be given to heating, insulating, or draining the pump. If you choose to drain the pump, first remove the drain plugs and drain

the suction and discharge lines. Carefully blow out the pump with compressed air to clear all internal cavities of fluid.

1D Recommended Spare Parts

FOR ROUTINE MAINTENANCE:
Only a complete set of "O" ring gaskets and a mechanical seal are recommended. Should additional components show wear, they are available from stock at the factory (see the C Series price brochure).

FOR SERVICING A PUMP THAT DOES NOT PRODUCE RATED CAPACITY OR HEAD :
"O" ring gaskets, impeller, mechanical seal, and pump casing.

FOR CRITICAL SERVICES:
A duplex installation, with two identical pumping units in parallel, is the safest, and many times the most cost effective choice where downtime cannot be tolerated.

C4 • C5 • C6 SERIES

2. Service

Pump Ends

- A. Preliminary
- B. Disassembly
- C. Inspection of Components
- D. Reassembly
- E. Testing and Final Adjustments

2A Preliminary

Before attempting any service on the pump or motor, disconnect the electrical power to the pump motor. If the pump and motor are to be removed as a unit, note the wiring configuration.

1. Disconnect the inlet and outlet piping before unbolting the pump and motor.
2. Unbolt the motor from the base and remove the unit. All work on the unit should be performed on an elevated workbench whenever possible.

The disassembly and reassembly procedures are broken into two sections:

- B — Disassembly
- D — Reassembly

An exploded view of the unit, Figure 1, is provided for referencing the numbers in the following procedures, i.e. (#84), motor bracket.

2B Disassembly

The following tools and equipment are needed for disassembly.

1. Soft plastic or wooden mallet.
2. 5/8" wrench or socket.
3. 10 mm socket wrench.
4. 13 mm wrench or socket.
5. 5 mm Allen wrench.

6. Penetrating oil.
7. 3/4" wood dowel (Approx. 6" long).
8. Small O.D. Snap Ring Pliers.
9. Cealube G or similar glycol base lubricant. (DO NOT use petroleum products.)

To disassemble the pump:

1. Remove all liquid from the pump.
2. Remove the casing (#108) by removing the jam nuts (#20) from the casing studs (#5). Slide the casing off and rest it on the studs.
3. Remove the impeller (#11) by removing the 10mm Bolt (#19) and washer (#41), then sliding forward.(may require a gear puller)
4. Remove the snap ring (#4) from the shaft using snap ring pliers.

5. Remove the impeller key (#23) from the shaft.
6. Remove the rotating element from the shaft. The element normally adheres tightly to the shaft and some force may be necessary to remove it. This is common and, if care is taken, the element can be reassembled and reused. **It is recommended that a new rotating element be used for reassembly.** DO NOT attempt to remove the seal using a screwdriver or other sharp object. Extensive damage to the shaft or element could occur.
7. Remove the motor bracket. Loosen and remove the four socket head screws (#33A) with a 5 mm Allen wrench. Note: The rotating element must be removed before the motor bracket can be removed. It is not necessary to remove the adjusting screws # 33.

8. Remove the seat portion of the seal from the motor bracket.

- a. Place the motor bracket face down on a flat surface.
- b. Look into the opening in the center of the motor bracket, you will see a portion of the seat.
- c. Insert the 3/4" dowel and, very gently, tap the seat until it drops out.
- d. Care must be taken with the seats. They are often a brittle material and are prone to breakage. **It is recommended that a new replacement seat be installed during reassembly.**

2C Inspection of Components

Thoroughly clean all parts. All components should be examined for wear and corrosion. Replace any parts that show visible wear.

The "O" rings and other elastomeric components should be replaced if they have been deformed or cut.

If seal components must be reused, carefully inspect for microscopic cracks and nicks. Scratches that might be ignored elsewhere can produce leakage if they are on seal carbons and seat wearing surfaces.

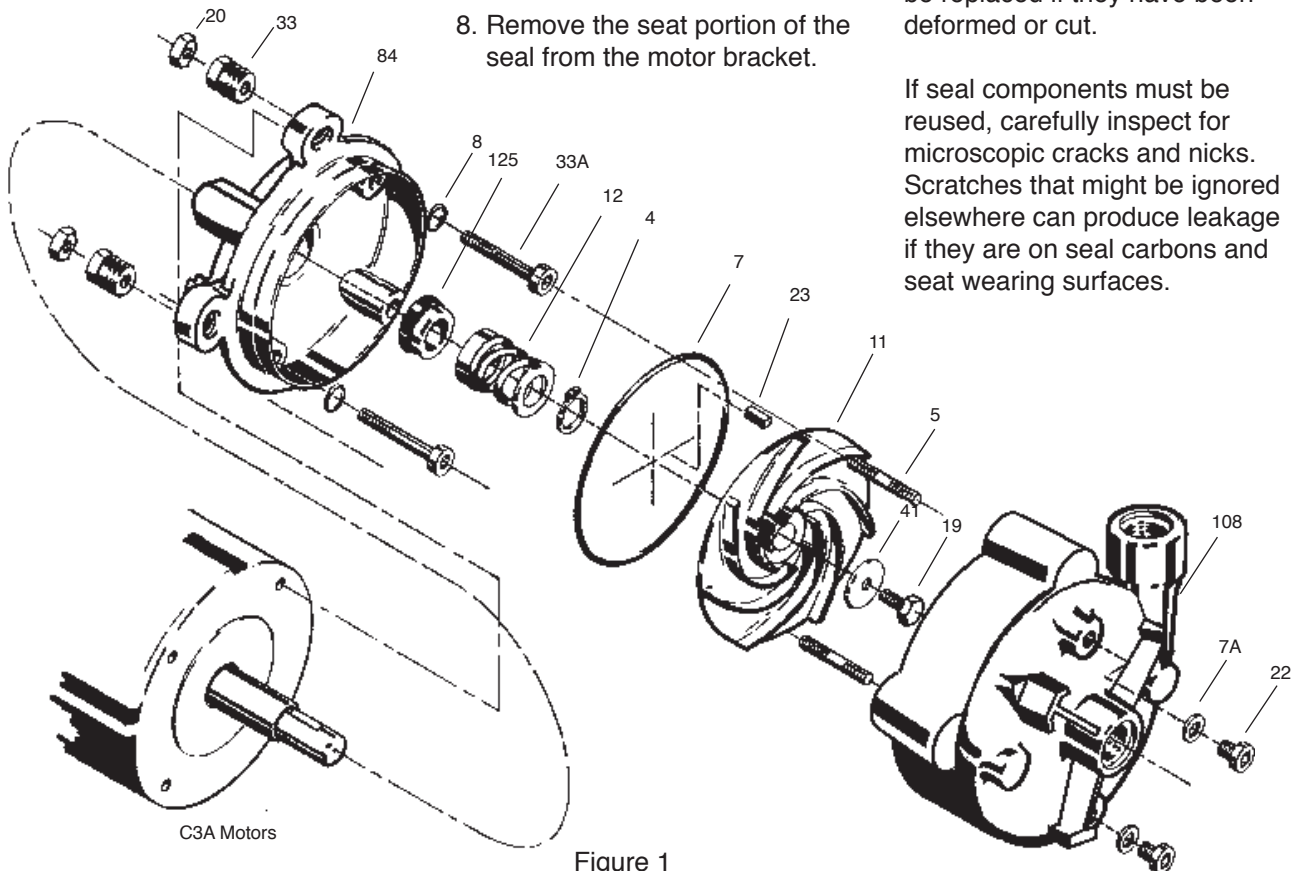

Figure 1

Service

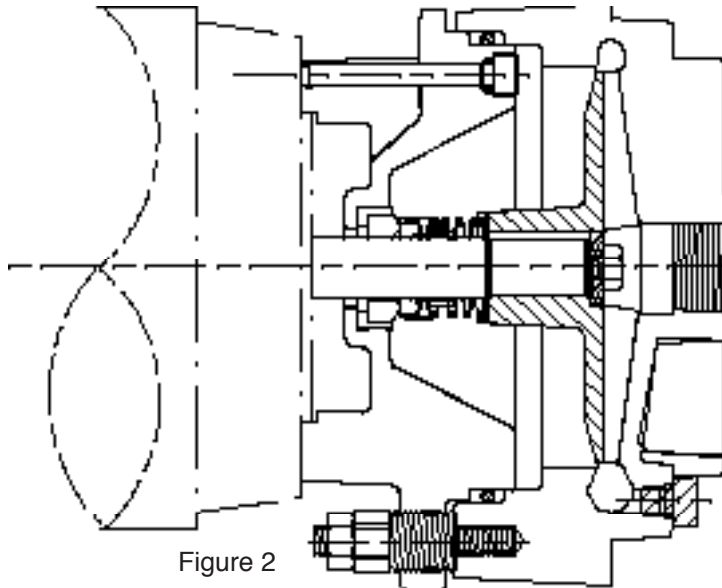

Figure 2

C SERIES PUMPS

NAME / DESCRIPTION	KEY NO.	QTY
Motor Bracket	84	1
Casing	108	1
"O" Ring - Casing**	7	1
Impeller	11	1
Seal - Rotating Element**	12	1
Seal - Stationary Seat**	125	1
Stud - Casing	5	4
Jam Nut	20	4
Adjusting Screw	33	4
Socket Head Screw	33A	4
"O" Ring - Screw**	8	4
Snap Ring**	4	1
Drive Key**	23	1
Impeller Screw	19	1
Washer	41	1
Drain Plug (SAE)	22	1
"O"Ring - Drain**	7A	1

**Included in SKC4100, SKC5100, SKC6100 Mechanical Seal / O Ring Kits

Cleanliness is imperative when working with mechanical seals. Microscopic grit and particles between seal faces can be, and often are, the cause of early seal failures.

If the impeller can be rocked or wobbled on the shaft, it is too loose and must be replaced.

Check the shaft for galling, pitting, and corrosion. If the shaft is corroded where the seal elastomer comes in contact with it, the motor must be replaced. Surface corrosion must be removed so that seals can slide freely during assembly. The shaft diameter should be no smaller than .002" below the nominal fractional seal sizes. Remove any nicks or burrs which may have occurred during disassembly. Re-clean parts as necessary.

2D Reassembly

All parts should be visually inspected and cleaned or replaced as outlined in 2C above.

1. The seal seat (#125) must be installed in the motor bracket before the bracket is installed on the motor.

To install the seat:

- a. Place the motor bracket face up on a flat surface.
- b. Carefully press the seat, smooth side up, into the seat cavity of the motor bracket. To make the installation of the seat easier, apply a very thin coating of compatible seal lubricant to the elastomer portion of the seat prior to installation. Care must be taken not to damage the seat face. Thumb pressure is usually sufficient to install the seat. Make sure the seat is installed firmly and squarely and that it is then carefully cleaned.

2. Install the motor bracket (#84).

- a. This is best done with the motor standing on end.
- b. From the motor side: If removed during disassembly, thread the four (4) adjusting screws (#33) into the mounting flanges of the motor bracket until they are flush with the front faces of the flanges.

c. Slide the four (4) small "O"-rings (#8) fully onto the socket head screws (#33A).

d. Place the motor bracket (#84) on the motor. Slide the bracket back until the feet are resting against the motor face. The orientation of the motor bracket is not critical unless a flush line is used. In that case, align the flush line to meet system requirements.

e. Insert the four (4) socket head screws (#33A) into the motor bracket holes and thread into the motor face. Tighten securely using a 5 mm allen wrench. Do not exceed 7 ft-lbs of torque or damage to the motor "C"-face may occur.

3. Install rotating element (#12).

- a. Tip the pump assembly over into a horizontal position on the work area.
- b. Lightly lubricate the motor shaft. Push the rotating element, spring, and then spring holder over the shaft.

Service

- c. Prepare the snap ring in the snap ring pliers and then compress and hold the seal spring slightly below the snap ring groove. Install the snap ring (#4). Make sure the snap ring is locked in the groove.
4. Install the impeller (#11).
 - a. Place the key (#23) in the shaft sleeve.
 - b. The impeller should slide on firmly, but easily, until it stops. Force should not be required to install the impeller in the correct position.
 - c. The impeller hub should be facing toward the motor.
 - d. Fasten the impeller using the washer (#41) and screw (#19). Tighten the screw securely (do not exceed 7 ft-lbs of torque), while holding the impeller stationary. **The impeller should not have any play or wobble.**
 5. Install the casing (#108).
 - a. Hand tighten four (4) studs (#5) into the casing until they are seated.
 - b. Lubricate and install the casing "O"-ring (#7) onto the first step in the motor bracket.
 - c. Place the casing over the motor bracket being careful not to pinch the "O"-ring. The casing discharge should be oriented to meet system requirements.
 - d. Loosely thread four (4) jam nuts (#20) onto the casing studs.
 6. Adjusting Impeller/Casing Clearance
 - a. Seat the casing down against the impeller with light hand pressure.
 - b. Turn the adjusting screws until they just touch the back face of the casing. The casing should not move during this adjustment. This will determine the zero clearance position. Set the minimum free running clearance as follows:
 - i. Viewing from the back of the motor bracket, (rear of motor) turn each adjusting screw clockwise exactly 30° (1/12 of a full revolution).
 - ii. Securely tighten the four (4) jam nuts against the adjusting nuts using a 9/16" wrench and a 5/8" wrench, being careful to prevent the adjusting nuts from turning.
 - c. Turn the impeller clockwise and listen for any scraping noises or interference. This may be done by turning the impeller screw with a 10 mm socket through the inlet port (Be careful not to loosen the screw), and listening through the discharge. If any contact is detected between the impeller and casing, perform the following steps:
 - i. Loosen the jam nuts, being careful not to turn the adjusting nuts.
 - ii. Repeat steps 6.b.i and 6.b.ii.
 - iii. Repeat step 6.c.

2E TESTING AND FINAL ADJUSTMENT

The pump is now ready for installation.

1. Reconnect the electrical connections referring to the colored or numbered tape used to mark the wires during disassembly.
2. Connect all piping and fill the pump with fluid.
3. Make sure all suction valves are opened and fluid will flow through the system. Discharge valve should be partially opened.
4. Start the pump and check for leaks on the pump and piping. Special attention should be given to the seal area at the rear opening in the motor bracket.
5. Using an amprobe or similar device, check for motor overload. If motor is overloading it is possible that the impeller clearance was not properly set as outlined in Step 6 outlined in "D" Reassembly.

C4 • C5 • C6 SERIES

3. Parts and Repair Services

- A. Parts
- B. Repair Service
- C. Warranty Service

6A Parts

Repair parts may be obtained through your local Authorized Fabtek Aero Distributor who may be found in the yellow pages or by going to www.FabtekAero.com

6B Repair Services

Repair service for an Aero pump should be obtained from the company through which it was purchased.

In the event this is not possible, the name and phone number of a nearby Fabtek Aero representative or distributor may be obtained by contacting Fabtek Aero. In the event that it is necessary to return the pump to the factory for repairs, remove all accessories attached to the pump. We cannot accept responsibility for their safe removal, storage, and return.

6C Warranty Service

All requests for warranty claims should be made through the company from which the pump was purchased or supplied. Complete details on what is wrong with the pump must be provided along with information on the system in which it is installed. Refer to the Aero Pumps Limited Warranty statement. Return authorization must be obtained prior to returning any equipment.

C4 • C5 • C6 SERIES

4. Limited Warranty

All requests for warranty claims should be made through the company from which the product was purchased or supplied. Complete details on reason for warranty request must be provided along with information on the system in which it is installed. Refer to the Fabtek Aero Limited Warranty statement below for more information. Return authorization must be obtained prior to returning any equipment.

Fabtek Aero, Ltd. / AERO Pumps, hereinafter referred to as "FABTEK AERO, LTD.", warrants for the period of 18 months from the date of shipment, unless otherwise stated below, (the "Warranty Period"), that the "Products" manufactured by it will be free from defects in material and workmanship.

PRODUCT	WARRANTY PERIOD
Pumps (except mechanical seals)	18 Months
Stainless Steel Tanks	5 Years

FABTEK AERO, LTD. will correct defects in material or workmanship, which may develop in its products under proper and normal use during the Warranty Period and under the conditions of this Warranty. This Warranty does not extend to anyone except the original

consumer-purchaser. Damage to the product due to improper handling, storage, maintenance, application, or installation is not covered by this Warranty. Warranty claims for motors, special items, or accessories not manufactured by FABTEK AERO, LTD. should be directed to those who manufactured the item. FABTEK AERO, LTD. will repair or replace, at its option and expense, its products proved to be defective after examination by an authorized representative of FABTEK AERO, LTD. The defective Product must be returned, transportation prepaid, to the factory at Plano, Illinois, USA. Disassembly of the equipment (especially pumps) impairs determination of reasons for failure and shall be cause for voiding this Warranty. The Product, repaired or replaced, will be shipped F.O.B. FABTEK AERO, LTD.'s factory. This is FABTEK AERO, LTD.'s sole warranty. FABTEK AERO, LTD. makes no other warranty of any kind, express or implied, and all implied warranties of merchantability and fitness for a particular purpose which exceed FABTEK AERO, LTD.'s aforementioned obligations are hereby disclaimed by FABTEK AERO, LTD. and excluded from this warranty. FABTEK AERO, LTD. neither assumes nor authorizes any person to assume for it, any other obligation

in connection with the sale of the Product and any enlargement of this Warranty by a purchaser shall be for its own account and its exclusive responsibility. This Warranty shall not apply to any Product or parts of Products which: (a) have been repaired or altered outside of FABTEK AERO, LTD.'s factory, in any manner; or (b) have been subjected to misuse, negligence or accident; or (c) have been used in a manner inconsistent with FABTEK AERO, LTD.'s printed instructions, specifications, or the customer supplied application specification; or (d) have been damaged due to defective power supply or faulty installation. FABTEK AERO, LTD. shall not be liable for incidental and consequential losses and damages under this express warranty, any applicable implied warranty, or claims for negligence, except to the extent that this limitation is found to be unenforceable under the applicable State law. Some States do not allow the exclusion or limitation of incidental or consequential damages, so the above limitation or exclusion may not apply to you. This warranty gives you specific legal rights, and you may also have other rights, which vary from State to State.

C4 • C5 • C6 SERIES

Installation Notes

Serial #: _____ Install Date: _____

Distributor Name: _____

Maintenance & Service Record

Date	Procedure	Result	
_____	New pump installation into system	Flow=	/Pressure=
_____	_____	_____	_____
_____	_____	_____	_____
_____	_____	_____	_____
_____	_____	_____	_____
_____	_____	_____	_____
_____	_____	_____	_____
_____	_____	_____	_____
_____	_____	_____	_____
_____	_____	_____	_____
_____	_____	_____	_____
_____	_____	_____	_____
_____	_____	_____	_____
_____	_____	_____	_____
_____	_____	_____	_____
_____	_____	_____	_____
_____	_____	_____	_____
_____	_____	_____	_____
_____	_____	_____	_____
_____	_____	_____	_____
_____	_____	_____	_____
_____	_____	_____	_____
_____	_____	_____	_____
_____	_____	_____	_____
_____	_____	_____	_____