

TANK ACCESSORIES

STAINLESS STEEL SIGHT GAUGE VALVE ASSEMBLY

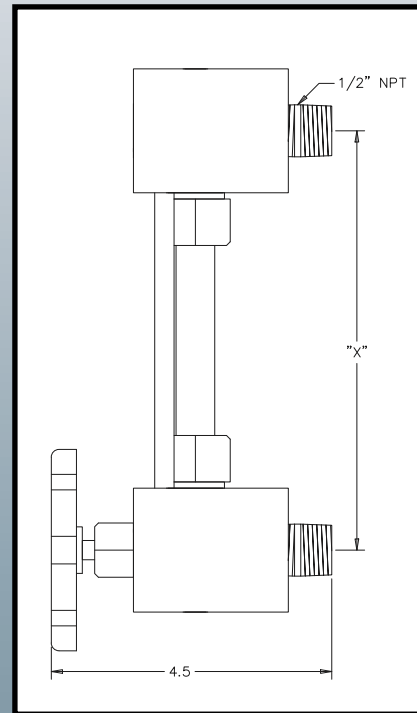

STAINLESS STEEL PUMP SUCTION ISOLATION VALVE

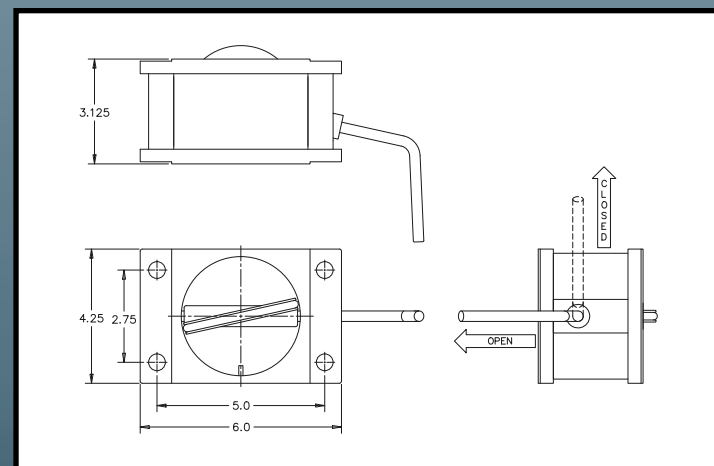

STAINLESS STEEL VACUUM CONDENSATE PUMP SERIES SSVCRU



**EXCEPTIONAL VALUE
EXTRAORDINARY QUALITY**

Standard Features

- 5000 – 65,000 EDR Capacities
- 2.6 to 36 CFM
- Cylindrical 304SS Receiver with Internal Accumulator Tank
- Investment Cast 304SS Centrifugal Pumps
- 304SS Orifice and Plate Housing
- NEMA 4/12 Control Panel

Available Options

- Stainless Steel Pump Suction Isolation Valves
- High Temperature Limit Switch

FABTEK



775 Duvick Avenue • Sandwich, IL 60548
Ph: 630.552.3622 • Fax: 630.552.8220
www.fabtekaero.com



775 Duvick Avenue • Sandwich, IL 60548
Ph: 630.552.3622 • Fax: 630.552.8220

www.fabtekaero.com

VACUUM CONDENSATE PUMP DIMENSIONS

TYPICAL APPLICATION

The vacuum condensate pump serves two main functions in a steam heating system. The first function is to remove air from the steam lines thus allowing faster heat transfer throughout the system. The second is to remove condensate which also allows the system to function quickly.

The Fabtek Series SSVCRU vacuum condensate units are available in simplex and duplex configurations. Capacities range from 5000 EDR to 65000 EDR with pump discharge pressures available in 20, 30 and 40 psi ranges.

HOW IT WORKS

As condensate loads increase or there is a call for vacuum, the SSVCRU will automatically start. As the liquid level in the accumulator tank rises high enough to trip the float switch, the air pumps will activate thus removing the condensate from the accumulator tank and dumping the condensate into the hurling tank. The same process occurs when the vacuum switch is activated.

As condensate levels in the hurling tank increase, the mechanical alternator will activate one condensate pump. After each cycle the pumps will automatically alternate. If the condensate load is too much for one pump to handle the second condensate pump will be started simultaneously.

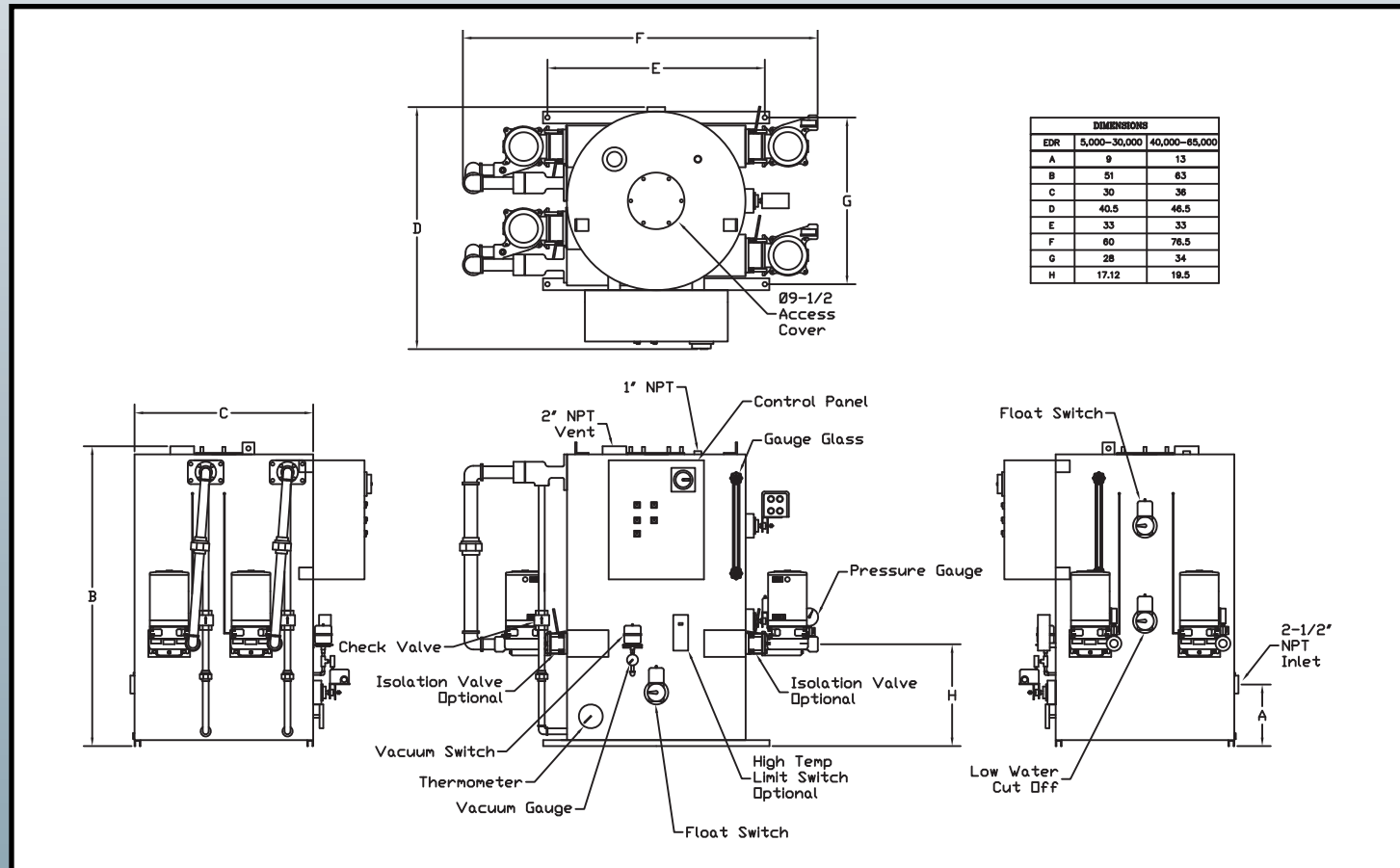

VACUUM PUMP SIZES		5	10	15	20	25	30	40	65
EDR		5000	10000	15000	20000	25000	30000	40000	65000
SIMULTANEOUS CAPACITY	WATER GPM	7.5	15	22.5	30	37.5	45	60	97.5
	AIR CFM	2.6	6.1	7.1	8.2	12.4	14.4	22	36
MOTOR HP AIR		3/4	1	1	1 1/2	2	3	3	5
WATER PUMP MOTOR HP	20 PSI	1/2	1/2	3/4	3/4	1	1	1 1/2	3
	30 PSI	3/4	3/4	1	1	1 1/2	1 1/2	2	5
	40 PSI	1	1	1 1/2	1 1/2	1 1/2	2	3	5
BTUM		1.2	2.4	3.6	4.8	6.0	7.2	9.6	15.6

Ratings are based on vacuum heating pump code of ASHRAE with 5.5 in HG at 160° F.

