

FABTEK

SERIES SSVCU VACUUM PUMP

INSTALLATION, OPERATION & MAINTENANCE MANUAL

775 Duvick Avenue • Sandwich, IL 60548
Ph: 630.552.3622 • Fax: 630.552.8220
www.fabtekaero.com

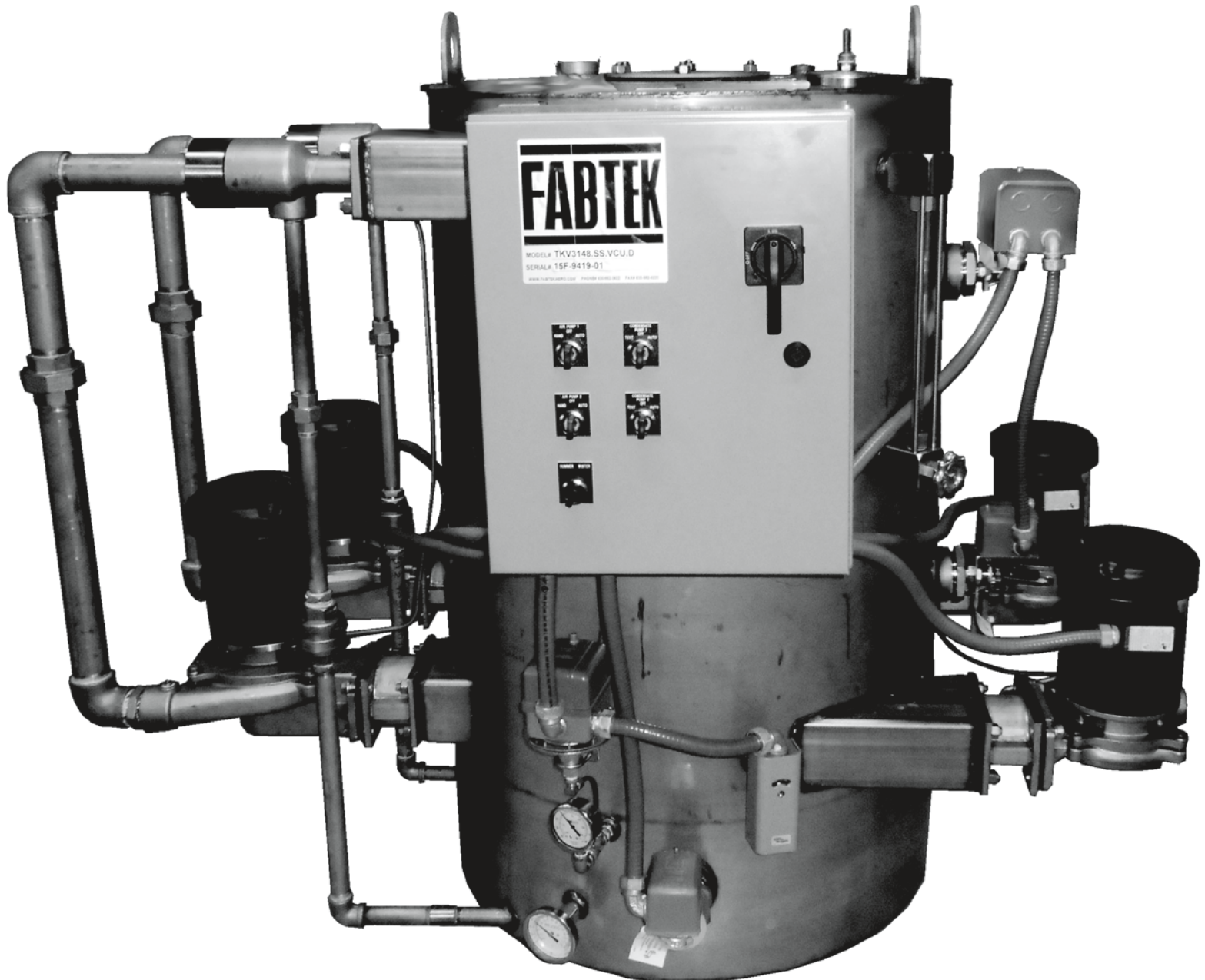

**EXCEPTIONAL VALUE
EXTRAORDINARY QUALITY**

INTRODUCTION

FABTEK series SSVCRU vacuum condensate pumps are factory built and tested to maintain vacuum and remove condensate and non-condensable gases from a steam heating system. These units are complete assemblies which include vacuum producing pumps which pump through exhauster assemblies, condensate return pumps, tanks, and controls. All units are factory tested to assure a leak free unit and to check and set all mechanical switches.

INSTALLATION

Upon delivery the unit should be checked for any shipping damage. If the unit is damaged, it is the responsibility of the customer to file a claim with the freight carrier.

Uncrating

The crates of each vacuum unit are screwed together. Remove the top section first. This is the main protection for the control panel. The front or back section can be removed next. The unit is now ready to be unbolted from the base.

Rigging

Make sure the installers use the lifting lugs on the unit for moving and positioning of the unit. If the lugs are not used this could void the warranty of the unit. The foundation for the vacuum pump should be made of concrete which is at least 3" above the floor. This pad needs to be level with 4 bolts protruding 1 1/2" above the concrete. These bolts need to be roughly 4" in overall length. The pump should then be shimmed level and grouted with cement. Once the cement has hardened, tighten down the hold down bolts.

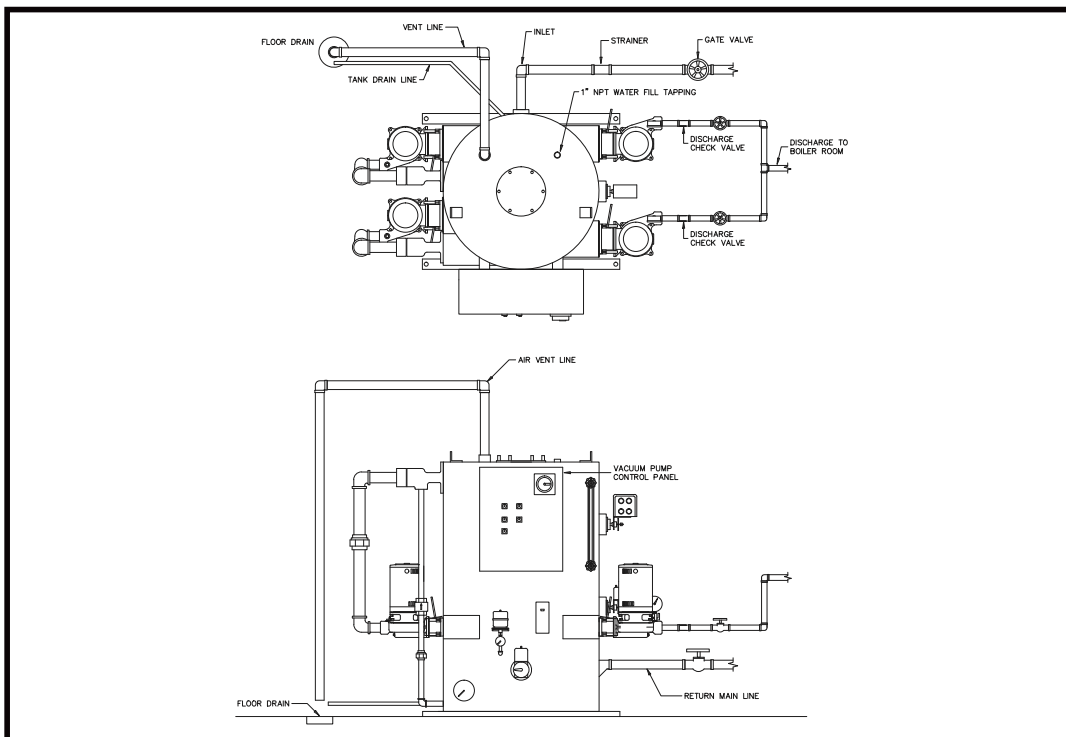

PIPING CONNECTIONS

All units are provided with heavy stainless steel threaded water inlet fittings. Installation of valves or strainers with pipe flanges is recommended for ease of installation. Threaded valves and strainers will also work if necessary. ALL piping should be supported by hangers.

A. Vent

The vent line plumbed into the top of the vacuum tank must be at least 12" above the water line in the boiler. This line MUST be equal to or larger than the tapping provided on the tank; this should never be reduced in pipe size. The vent line should be piped to the ceiling if possible and it should terminate over a floor drain.

B. Condensate Discharge to Boiler Room

The discharge lines from the condensate pump to the boiler room should be the same pipe size or large than the pump discharge tapplings. Increasing the pipe size will allow for better flow and less noise. Each condensate pump discharge line should have a check valve and a shut off valve plumbed into their individual lines. If the discharge line to the boiler room is a long distance or is above the boiler waterline, a second check value should be installed at the boiler return header. This will help prevent noisy operation of the check valves by sudden pressure variations. Hartford connection must be used on all systems to prevent backward flow into the return main of vacuum pump. A bypass connection is recommended on systems where the end of the return main is 2 feet or more above the boiler water line to permit condensate to return to the boiler if there is a power failure.

C. Return Main

NEVER connect steam returns from equipment or common returns which carry high pressure steam to the vacuum return mains or to the vacuum pump high pressure steam returns MUST be piped through a properly sized flash tank or economizer prior to connecting them to the vacuum return mains. Return mains should be sloped downward toward the vacuum pump accumulator tank (bottom inlet tapping on the tank).

D. Equalizer Connections

A $\frac{3}{4}$ " equalizing line should be installed between the steam main and return main through a swing check valve and hand valve.

E. Water Fill

A 1" NPT tapping is provided in the top of the vacuum tank for water filling. A permanent line may be plumbed into this tapping but it is not necessary. The tank can be filled by a garden hose if you choose. Tank must be filled until the water is about half way up the sight glass. This will probably be the last time you will add water to the unit. Make sure all drain plugs and pipe connections are tight and there are no leaks. Remove all shipping brackets on float switches and alternators

F. Electrical Connections

Make sure the incoming power matches the vacuum pump control panel power requirements. The only wiring required of the vacuum pump is the incoming power. All field wiring is to be in accordance with the National Electric Code and must meet Federal, State and local codes.

PRELIMINARY START UP CHECKLIST

1. Make sure all plumbing connections are tight. All drain plugs are installed and tight. Gate valves for the condensate return main and discharge main are closed.
2. Fill upper hurling tank with water until sight glass is half full. Make sure all shipping brackets are removed from float switches and alternators.
3. Check to make sure incoming power matches the control panel requirements. Make sure the circuit breakers have not tripped inside the panel. Close the door and turn on the main power disconnect to the panel. Individually "bump" each pump to check for correct rotation. Use either the HOA or TOA switch for each pump, the rotation should be clockwise when looking down at the motor. Look at the motor fan to see rotation or remove the motor end cap to view rotation.
4. Vacuum switches are preset to turn on at 2" of vacuum and shut off at 9" of vacuum. If a high temp limit switch is used it is preset to 180 F

AUTOMATIC OPERATION

Once all items have been inspected and checked the unit can be placed in automatic operation. Simply switch all the TOA and HOA switches to the AUTO mode. The operating principles of the RVP and RVPD are simple. As condensate loads increase or there is a call for vacuum, the unit will automatically begin its service. If the liquid level in the accumulator tank rises high enough to trip the float switch, the air pumps will activate, thus remove the condensate entrained air and gases from the accumulator tank and dumping the condensate into the hurling tank. The same process happens if the vacuum switch is activated.

As condensate levels in the hurling tank increase, a mechanical alternator will activate one condensate pump, thus pumping water to the boiler room. Each time the alternator is activated the pumps will automatically alternate. If the condensate load is too much for one pump to handle the second pump will also be activated simultaneously.

TROUBLESHOOTING

- 1.** If no pumps run in hand or automatic mode, check the following:
 - a. Make sure the tank has enough water in it to deactivate the low water cutoff float switch.
 - b. Make sure a circuit breaker hasn't tripped.
 - c. Make sure main through-the-door disconnect is ON.
 - d. Check incoming power.
- 2.** If condensate pumps run, but don't develop adequate pressure check the following:
 - a. Check motor rotation. The correct rotation is clockwise when viewed from the back of the motor. If rotation is backwards on a 3 phase unit simply switch any two leads. Since all units are tested at the factory, any motor which runs backwards will result in ALL motors running backwards. Change any two incoming main power leads.
 - b. Adjust the discharge gate valve to get the correct pump pressure.
 - c. Make sure all electrical connections are tight
- 3.** With air pumps running, close the valve in return main. With no air leakage around the pump, a vacuum on accumulator tank should be created rapidly as shown by vacuum gauge, and the vacuum switch will stop the pump. If this does not happen then check the following for tightness, after first proving that the vacuum gauge is functioning properly (suction connections). Also, make certain that the air check(s) on accumulator tank vent(s) contain the small loose disc furnished as a part of the assembly. This disc must be in place and clean to prevent the re-entrance of air into the tank. Diaphragm of vacuum regulator could be ruptured and a source of air leakage.

- 4.** If still unable to create satisfactory vacuum then the nozzles in the exhauster assembly should be removed and cleaned for foreign matter. Be sure to reassemble all parts tightly, replacing and damaged gaskets. If pump operates satisfactorily with valve in return main closed, but is unable to produce sufficient vacuum on the system when return main valve is opened, check the following:
- a. Clean the strainer in the return main.
 - b. Check for priming boiler. IF the boiler is dirty, large quantities of water will be carried into the system causing pump to handle excessive amounts of water. To handle for priming boiler, pull open the safety valve when the boiler is carrying a few pounds of steam pressure. If clean, "white" steam comes out, boiler water is satisfactory. If dirty water is discharged from the safety valve, the boiler should be blown off from top to remove the oil and sludge while steam pressure is maintained and city water added to maintain boiler water level for a period of three hours or more.
 - c. Check for air leaks into system. If pump is exhausting air from the system and discharging it at the vent, yet does not build up a vacuum, it indicated that there air leaks in the system. The easier way to check for air leaks is to shut down the pump or operate it at sort intervals on "test" control after removing disc from air check and carry a few pounds of steam pressure consistently on the boiler, permitting no vacuum to be created in return lines. A leak whether on steam or return side of system, will be shown by dripping water. Where piping is concealed, run the pump on "AUTO". Fill all the radiation with steam under pressure and then shut off boiler fire as quickly as possible, or if there is a valve in the outlet of boiler close it. The condensing of steam in radiation together with air exhausted by pump it will create a vacuum on the system. By listening particularly in the basement, the leak of air can be heard.
 - d. Check for steam entering return lines through an open connection or through some steam traps not seating properly. The hottest return line usually indicates the source of the trouble. The source of such trouble is usually in drip traps on the ends of steam mains or risers where scale and rust collect. It is rather uncommon to find such trouble in radiator traps. If steam is supplied to apparatus at higher pressures than is carried on the heating system, the return piping from this apparatus should not be carried directly into the heating system returns unless means are provided to dissipate the excess heat. Where this is not possible, other means of handling the condensate form medium or high pressure returns to boiler must be employed.
 - e. Should the water level rise in tank and overflow vent while the pump is in operation, the float may have come off the alternator as the alternator switch may have a malfunction. To check to see if the float has fallen off the alternator, simply move the float arm to check for the weight of the float.
 - f. If the water gauge glass shows water rising in the tank, rapidly after vacuum pump stops automatically the check valve in discharge line to boiler is leaking and should be repaired or replaced.
 - g. If vacuum falls very rapidly when pump stops automatically on the "Automatic" control starting and stopping the pump at frequent intervals, in all probability, the check valve in nozzle suction is leaking and must be replaced, or the strainer in return main is clogged and needs to be cleared.
 - h. If pump does not start, reset the circuit breaker switch of the started. This is a means of providing protection for the motor against overload of phase failure. With main switch open, examine the contact of the various switches and fuses to make certain there is a source of power to motor. IF on 3-phase current, the pump motor will not run, but merely hums, a fuse in the line has probably blown and needs to be replaced or a circuit breaker has tripped. If on a single phase, the commutator of motor is dirty or the brushes need to be adjusted.
 - i. If no pumps start, check incoming power. Make sure all circuit breakers are reset and fused are not blown. If pumps still fails to start, check hurling tank to make sure there is a sufficient amount of water to trip the low water cutoff switch.

MAINTENANCE

A. Periodic Checks

Maintenance of the vacuum pump is minimal and most problems can be eliminated through periodic checks of the unit.

1. Monthly periodic checks and maintenance should be accomplished to be sure that all sight glasses are kept clean and that the pressure and vacuum gauges and the thermometers are operating properly.
2. Every year the following checks are maintenance should be completed.
 - a. The tank should be flushed to prevent mineral build-up.
 - b. Float and/or alternating float switches and vacuum switches should be checked to assure proper operation.
 - c. The pump(s) and tank should be checked to determine if they are capable of producing and holding the required vacuum.
 - d. The nozzle suction check valves should be checked to make sure they don't leak.

B. Care of Pump

Lubricate the motor bearings according to the motor manufacturer's recommendations.



SQUARE D

Instruction Bulletin

Reference No. 9037-891
Bulletin No. 65013-013-90C
Raleigh NC, USA, April, 1995
Supersedes 65013-013-90B dated 10/94

Closed Tank Float Switch Class 9037 Type HG, Series A

INTRODUCTION

This document contains installation, operation, adjustment and parts replacement information for Class 9037 Type HG Series A Closed Tank Float Switches. These float switches are used to automatically control the liquid level in closed tanks.

CAUTION

EQUIPMENT DAMAGE HAZARD.

Remove shipping bracket from mounting plate before installing switch.
Failure to observe this precaution can result in equipment damage.

EXCESSIVE PRESSURE.

Avoid using the float switch where pressure within the closed tank exceeds 50 psi.

Failure to observe this precaution can result in seal leakage and equipment damage.

MOUNTING

To mount the float switch (refer to Figure 1):

1. The float switch is shipped with a bracket attached to the mounting plate. This bracket prevents the float and rod from moving in the tank during shipment. Remove and discard this clearly-marked shipping bracket before installing the float switch.
2. Loosen the nut (item C) so that the 2-1/2 inch I.P.S. threaded fitting (item D) rotates freely in the switch bracket.
3. Mount the float switch by screwing the threaded fitting directly to the tank.
4. Tighten the threaded fitting so no fluid from the tank leaks past the threads.
5. Rotate the switch case until it is horizontal and tighten the nut.

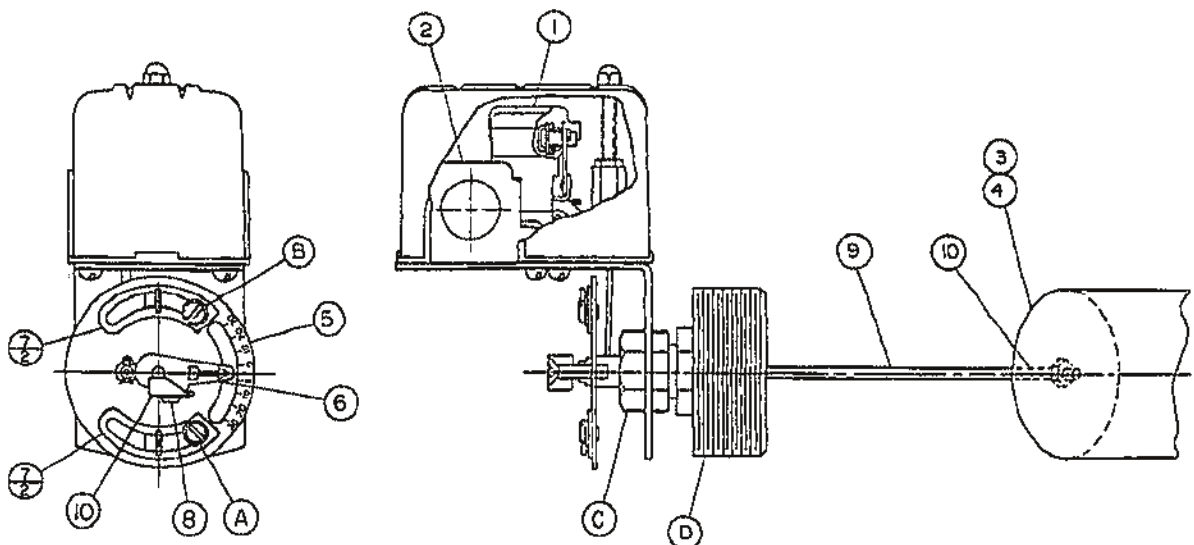

Figure 1 Class 9037 Type HG Series A Float Switch

ENCLOSURE RATING

NEMA 1 enclosures are intended for indoor use primarily to provide a degree of protection against contact with the enclosed equipment in locations where unusual service conditions do not exist.

ADJUSTMENT

⚠ DANGER

HAZARDOUS VOLTAGE.

Disconnect all power before working on equipment.

Failure to observe this precaution will result in severe injury or death.

Float switches are shipped from the factory set for a specified float travel. Some adjustment of float travel can be made in the field. Float travel is adjusted by moving one or both of the adjusting strips (item 7 in Figure 1), held in place by screws (items A and B).

To change the upper limit of float travel:

1. Loosen screw (item B).
2. Move the upper adjusting strip (item 7) clockwise to reduce the upper limit or counter-clockwise to increase the upper limit.
3. Tighten the screw (item B).

To change the lower limit of float travel:

1. Loosen screw (item A).
2. Move the lower adjusting strip (item 7) counter-clockwise to reduce the lower limit or clockwise to increase the lower limit.
3. Tighten the screw (item A).

Reverse Action

Standard float switches are shipped from the factory with the float and link positioned for contacts to close on liquid rise. Form R float switches are shipped with the float and operating link positioned for contacts to open on liquid rise. To reverse the switch action, relocate the operating link to the opposite slot in the base plate and to the corresponding hole in the adjusting plate (refer to Figure 2).

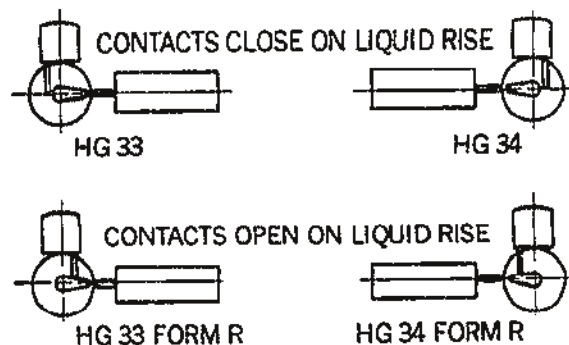

Figure 2 Float and Link Positions

MOTOR PROTECTION

This type of float switch does not provide motor protection but is frequently used as a pilot to operate a motor protective starter. For more information on the complete line of motor protective switches, contact your local Square D Sales Office.

WIRING AND ELECTRICAL RATINGS

Figure 3 shows typical single phase and polyphase wiring diagrams for the float switch. The switch contact control circuit has an A600 rating. Horsepower ratings for the switch contacts are listed in Table 1.

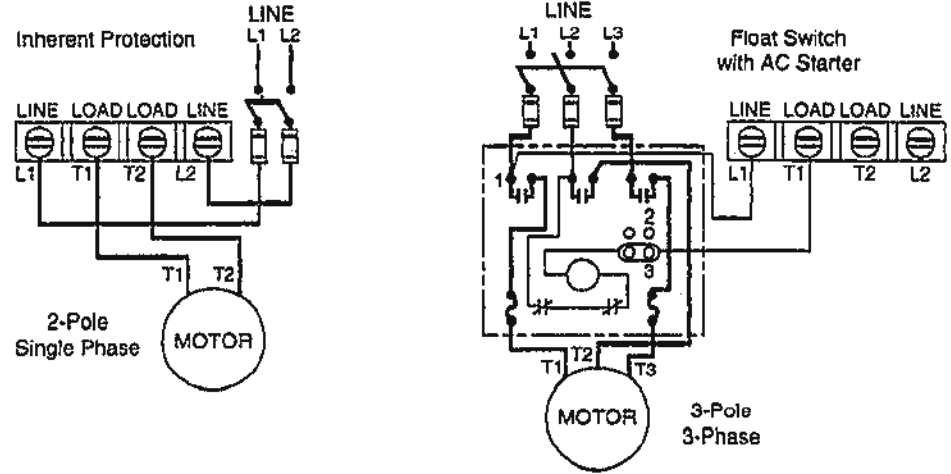

Figure 3 Wiring Diagrams

Table 1 Switch Contact Horsepower Ratings

Voltage	Horsepower Ratings		
	Single Phase AC	Polyphase AC	DC
115	2 hp	3 hp	1/2 hp
230	3 hp	5 hp	1/2 hp
460/575	—	1 hp	—
32	—	—	1/4 hp

REPLACEMENT PARTS

Replacement parts for the Class 9037 Type HG Float Switch are listed in Table 1. For parts locations, see Figure 1 on page 1. When ordering parts, always give Class, Type and Form of switch.

Table 1 Replacement Parts

Item No.	Description	Quan.	Part No.
1	Set of Moveable and Stationary Contacts	2	9998 PC-242
2	Switch Mechanism ⁽¹⁾	1	65079-502-51
3	Float (304 SS)	1	9049 HF3
4	Float (316 SS)	1	9049 HF4
5	Adjusting Plate Assembly	1	2810-D7-G1
6	Operating Lever	1	2810-C4-X2
7	Adjusting Strip	2	2810-X8
8	Screw	1	21911-14161
9	Connector and Rod Assy.	—	1 2810-C3-G9
	90° Offset	3"	1 2810-C3-G15
	90° Offset	4-1/4"	1 2810-C3-G19
	90° Offset	5"	1 2810-C3-G18
	90° Offset	7"	1 2810-C3-G6
10	Clamp	1	2810-D4-X1
—	Seal and Installation Kit (BUNA-N)	1	9998 PC-337
—	Seal and Installation Kit (VITON®)	1	9998 PC-338

⁽¹⁾ Orders for mechanisms must show Class and Type so nameplate on replacement can be correctly stamped.



**Class 9038 CR Series A MECHANICAL ALTERNATOR
For Hazardous Locations — NEMA 7 and 9, Class 1 and 2 Group C thru G
and
Class 9038 CW Series A MECHANICAL ALTERNATOR
For Water Tight Applications — NEMA 4**

CAUTION: Switches are shipped with a bracket attached to the mounting plate. This bracket prevents the float and rod from moving in the tank during shipment. When installing the system, this clearly marked shipping bracket must be removed and discarded.

APPLICATIONS: The Class 9038 Type C Mechanical Alternators serve to open and close an electric circuit by an upward and downward float movement. The forces are applied by means of a float operating between different liquid levels. The action is such that two switch units are alternated on successive cycles. If the liquid level continues to rise or fall with one pump in operation, the lever will continue to travel to a further position at which point the "second" switch will be operated, throwing the stand-by pump across the line.

MOUNTING: The Class 9038 Type C Mechanical Alternators are mounted directly to the tank by means of the 2½" I.P.S. threaded fitting (D). Before screwing this fitting into the tank, loosen Nut (C) so that the fitting (D) is free to rotate in the switch bracket. Tighten the fitting (D) so that there will be no leak past the threads. Then revolve the switch case until it is horizontal and tighten Nut (C).

PRESSURE: In the use of the C Alternators, the pressure limit within the closed tank must not exceed 100 psi.

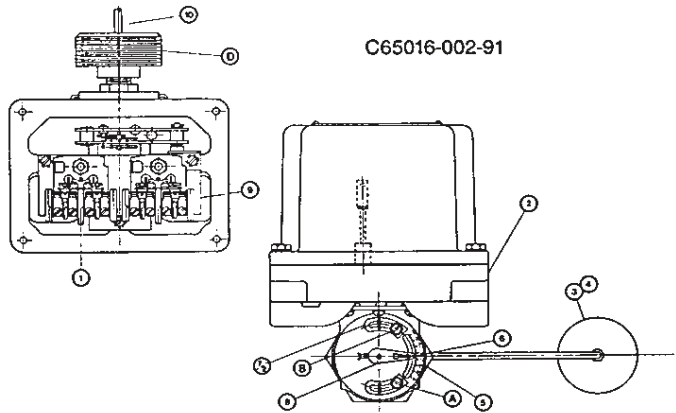

ELECTRICAL RATINGS (HORSEPOWER)

Voltage	Single Phase AC	Polyphase AC	DC
115	2HP	3HP	½HP
230	3HP	5HP	½HP
460/575		1HP	
32			¼HP

Control Circuit Rating: A600

REVERSE OPERATION: Form R controls are arranged for reverse action. In this form, the contacts will open on increase in liquid level. It is not recommended that a change be made in the field from standard to reverse operation or vice versa.

MANUAL TRANSFER (LEAD-LAG) SELECTOR: Form N3 switches have a manually engaged selector which voids alternation. The pump selected to lead always comes on first. With selector disengaged, the unit reverts to normal alternation.

MOTOR PROTECTION: A control of this type does not afford motor protection. However, it is quite frequently used as a pilot to operate a starter providing this desirable feature. The Square D Company manufactures a complete line of motor protective devices, information on which will be sent upon request.

WARNING: TO AVOID SHOCK HAZARD, DISCONNECT ALL POWER BEFORE INSTALLING OR SERVICING DEVICE.

ADJUSTMENTS: Switches are shipped from the factory set for a specified float travel. Reasonable adjustment of float travel can be made in the field by moving adjusting strips (7) which are held in place by Screws (A) and (B). Loosening Screw (B) and moving upper adjusting strip (7) will affect the upper limit of float travel only. Loosening Screw (A) and moving lower adjusting strip (7) will affect the lower limit of float travel.

REPLACEMENT PARTS LIST

Item Number	Description	Number Req'd.	Part Number
1	Set of Movable and Stationary Contacts	2	9998 PC-242
2	Gasket (CW)	1	1551-D20-X1
3	Float (304 SS)	1	9049 HF3
4	Float (316 SS)	1	9049 HF4
5	Adjusting Plate Assembly	1	2810-D7-G1
6	Operating Lever	1	65079-042-01
7	Adjusting Strip	2	2810-X8
8	Set Screw	1	21801-14080
9	Switch Mechanism, Types CR, CW-31, 33, 35	1	1551-B19-G5
9	Switch Mechanism, Types CR, CW-32, 34, 36	1	1551-B19-G2
10	4½" Connector and Rod Assy.	1	2810-C3-G20
10	5" Connector and Rod Assy.	1	2810-C3-G21
10	7" Connector and Rod Assy.	1	2810-C3-G22
—	Seal and Installation Kit (BUNA-N)	1	9998 PC-337
—	Seal and Installation Kit (VITON)	1	9998 PC-338

Replaces 9037-894
Dated March, 1988

June, 1988



MADE IN USA



*WHERE SEPARATE POWER SUPPLIES ARE PROVIDED THE DISCONNECT MEANS FOR EACH MOTOR MUST BE GROUPED TOGETHER AND PROVIDED WITH SUITABLE WARNINGS IN ACCORDANCE WITH THE NATIONAL ELECTRICAL CODE AND ALL OTHER APPLICABLE CODES AND STANDARDS.

CLASS 9038 MECHANICAL ALTERNATOR - WIRING DIAGRAMS*

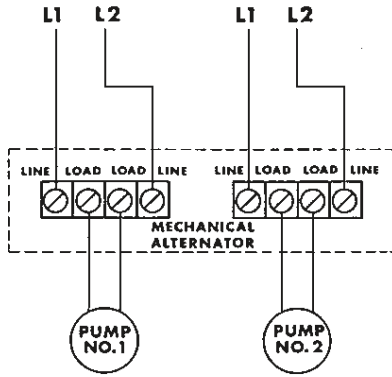

SINGLE PHASE MOTOR CONTROL

C65016-004-33

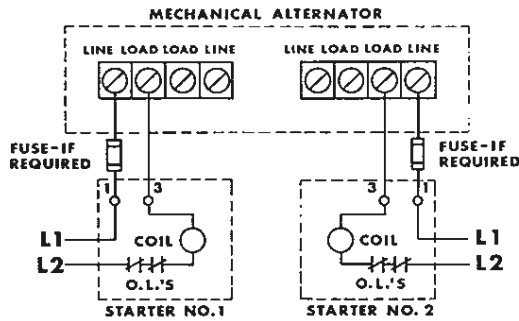

AC OPERATION OF MOTOR STARTERS

**ELECTRICAL RATING OF ALARM SWITCH ONLY
CLASS 9007 TYPE AO1**

AC PILOT DUTY			D.C. PILOT DUTY SINGLE THROW			
VOLTS	BREAK	MAKE	VOLTS	115	220	600
110	15A	40A	AMPS	0.5 A	0.25A	0.05A
220	10A	20A	DOUBLE THROW			
440	6A	10A	VOLTS	115	220	600
600	5A	8A	AMPS	0.25A	0.1	—

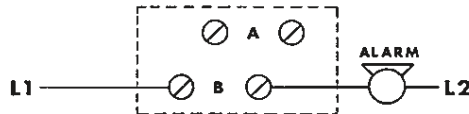

CIRCUIT A CLOSSES ON FALLING LIQUID LEVEL
CIRCUIT B CLOSSES ON RISING LIQUID LEVEL
(SWITCH CONTACTS MUST BE SAME POLARITY)
FORM N5 HIGH LEVEL ALARM

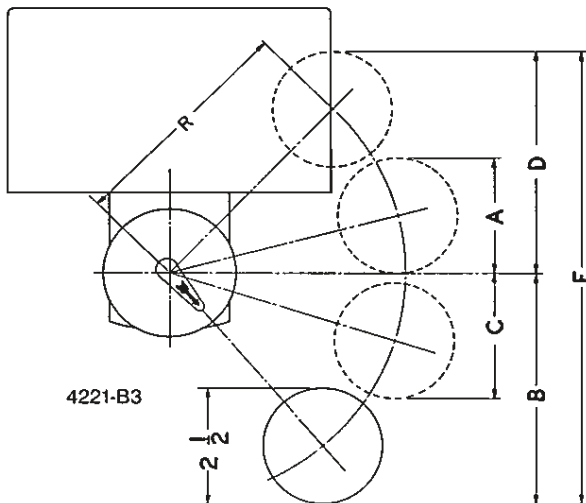

EXPLANATION OF FLOAT TRAVEL AND POSITION

NORMAL OPERATIONS: Switches will cut in and cut out at the high point and low point of distance A plus B, given in the tables. Under normal conditions, as long as one pump alone is able to handle the incoming water, the pumps will alternate at this distance. With the water level continuing to rise, the second switch will cut in and start the second pump when the float reaches the top of distance D. Both pumps will continue to run until the float returns to the low point of distance D plus C, where one pump will cut out. The other pump will continue until the float reaches the low point of distance B.

TYPE CR, CW



Vacuum Switch
Interruptor al vacío
Intérupteur à vide

Class Clase Classe	Type Tipo Type	Series Serie Série
9016	GVG 1	C

INTRODUCTION

This vacuum switch is a 2-pole, NEMA 1 enclosure switch for controlling vacuum pumps.

INTRODUCCION

Este interruptor al vacío es un interruptor de 2 polos que viene en un gabinete NEMA tipo 1 para el control de bombas al vacío.

INTRODUCTION

Cet interrupteur à vide est un interrupteur bipolaire sous coffret NEMA type 1 pour la commande des pompes à vide.

⚠ DANGER / PELIGRO / DANGER

HAZARDOUS VOLTAGE

Disconnect all power before working on equipment.

Failure to follow this instruction will result in death or serious injury.

TENSION PELIGROSA

Desenergice el equipo antes de efectuar cualquier trabajo en él.

El incumplimiento de esta precaución podrá causar la muerte o lesiones serias.

TENSION DANGEREUSE

Coupez l'alimentation avant de travailler sur cet appareil.

Si cette précaution n'est pas respectée, cela entraînera la mort ou des blessures graves.

⚠ CAUTION / PRECAUCION / ATTENTION

EXCESSIVE POSITIVE PRESSURE

Do not use a vacuum switch where positive pressure exceeds 30 psi.

Failure to observe this precaution can result in injury or equipment damage.

PREISION POSITIVA EXCESIVA

No utilice un interruptor al vacío donde la presión positiva exceda 21 kg/cm² (30 lbs-pulg²).

El incumplimiento de esta precaución puede producir lesiones o daño al equipo.

PRESSION POSITIVE EXCESSIVE

N'utilisez pas l'interrupteur à vide lorsque la pression positive dépasse 21 kg/cm² (30 lbs-pulg²).

Si cette précaution n'est pas respectée, cela peut entraîner des blessures ou dommages matériels.

MOUNTING

See Figure 1. Under conditions of moderate vibration and if connected to a short length of rigid steel pressure pipe, this switch may be mounted and supported by its vacuum connector (C). For added mounting support, use the flange mounted bracket (3). The mounting bracket kit is ordered separately (Class 9049 Type A 53).

MONTAJE

Vea la figura 1. Bajo condiciones de vibración moderada y si se conecta a un tramo corto de tubo de presión de acero rígido, este interruptor se puede montar y sostener con el conector de vacío (C). Para obtener soporte de montaje adicional, utilice el soporte montado sobre el borde (3). El accesorio del soporte de montaje se solicita por separado (clase 9049 tipo A53).

MONTAGE

Voir la figure 1. Dans des conditions de vibration modérée et lorsqu'il est raccordé à un tuyau de pression court en acier rigide, cet interrupteur peut être monté et supporté par son connecteur de vide (C). Pour fournir davantage de support au montage, utiliser le support monté sur bride (3). Le kit de support de montage est commandé séparément (classe 9049, type A 53).



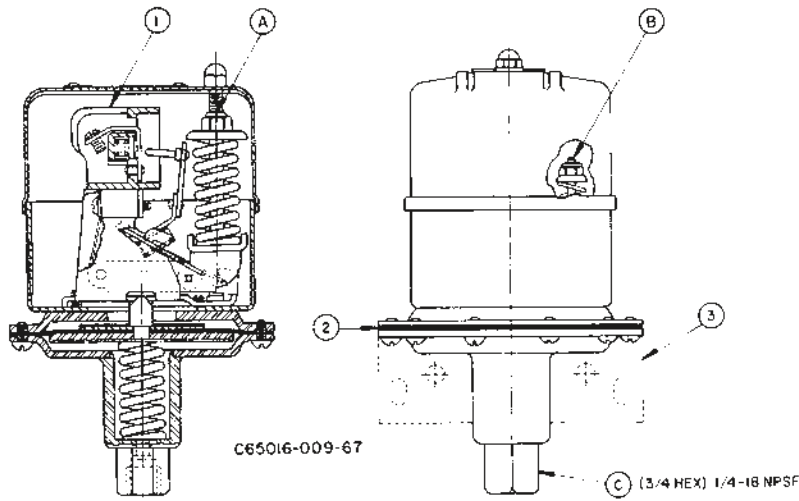

Figure / Figura / Figure 1 : Vacuum Switch / Interruptor al vacío / Intérrupteur à vide

WIRING AND ELECTRICAL RATINGS

Figure 2 shows typical single-phase (motor controller) and polyphase (control circuit switch) wiring diagrams. The switch contact control circuit has an A600 rating. Horsepower ratings for the switch contacts are listed in Tables 1 & 2.

CABLEADO Y VALORES NOMINALES ELECTRICOS

En la figura 2 se muestran los diagramas de cableado de una fase (controlador del motor) y polifásico (interruptor del circuito de control) típicos. El circuito de control del contacto del interruptor tiene un valor nominal de A600. La capacidad en kW de los contactos del interruptor se listan en las tablas 1 y 2.

CÂBLAGE ET VALEURS NOMINALES ÉLECTRIQUES

La figure 2 montre les schémas de câblage monophasé (contrôleur de moteur) et polyphasé (interrupteur de circuit de commande) typiques. Le contact d'interrupteur du circuit de commande a une valeur nominale de A600. Les valeurs nominales en HP des contacts de l'interrupteur sont indiquées dans les tableaux 1 et 2.

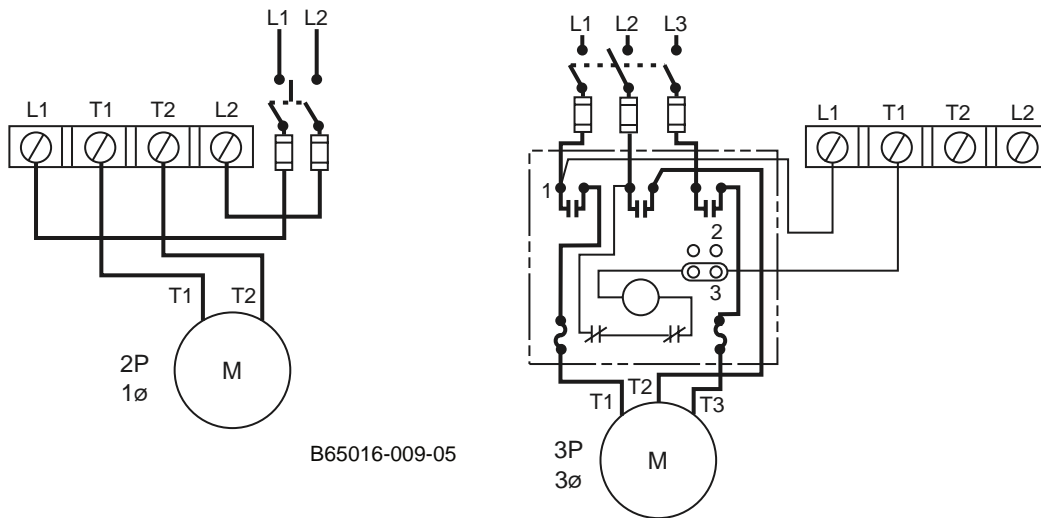

Figure / Figura / Figure 2 : Wiring Diagrams / Diagramas de cableado / Schémas de câblage

**Table / Tabla / Tableau 1 : Two-Pole Horsepower Ratings / Capacidades en HP (kW) de dos polos
Valeurs nominales en HP bipolaire**

Voltage Tensión Tension	Single-Phase AC Corriente ~ (ca) de una fase Courant CA monophasé	Polyphase AC Corriente ~ (ca) polifásica Courant CA polyphasé	DC --- (cd) CC
115 V~	2 HP (1,5 kW)	3 HP (2,2 kW)	1 HP (0,7 kW)
230 V~	3 HP (2,2 kW)	5 HP (3,7 kW)	1 HP (0,7 kW)
460-575 V~	5 HP (3,7 kW)	5 HP (3,7 kW)	-
32 V~	-	-	0.5 / 0,5 HP (0,4 kW)

**Table / Tabla / Tableau 2 : Single-Pole Horsepower Ratings (Form H) / Capacidades en HP (kW) de un polo
(Forma H) / Valeurs nominales en HP unipolaire (Forme H)**

Voltage Tensión Tension	Single-Phase AC Corriente ~ (ca) de una fase Courant CA monophasé	DC --- (cd) CC
115 V~	1 HP (0,7 kW)	0.5 / 0,5 HP (0,4 kW)
230 V~	2 HP (1,5 kW)	0.5 / 0,5 HP (0,4 kW)
460-575 V~	2 HP (1,5 kW)	-

**Table / Tabla / Tableau 3 : Operating Temperature Range / Gama de temperaturas de funcionamiento
Gamme des températures de fonctionnement**

Ambient Ambiente Ambiante	Pressure Media Medios de presión Milieux sous pression
Min. / Mín. -18 °C (0 °F)	Min. / Mín. -30 °C (-22 °F)
Max. / Máx. +107 °C (+225 °F)	Max. / Máx. +120 °C (+250 °F)

Note: Maximum allowable positive pressure: 30 psi

Nota: Presión positiva máxima aceptable: 21 kg/cm² (30 lbs-pulg²)

Remarque : Pression positive maximale autorisée : 21 kg/cm² (30 lbs-pc²)

ADJUSTMENT**Range**

Adjust the range spring nut (A) first until the desired vacuum operating point is obtained (see Figure 1). This adjustment changes both the high and low operating points but should always be used to set the higher vacuum operating point. Turn the nut clockwise to decrease (lower vacuum) both operating points. The range spring nut (A) adjusts the high and low operating points simultaneously. It does not change the differential.

AJUSTE**Gama**

Primero ajuste la tuerca de resorte de la gama (A) hasta que obtenga el punto de funcionamiento al vacío deseado (vea la figura 1). Este ajuste cambia tanto el punto de funcionamiento alto y bajo pero siempre se debe usar para fijar el punto más alto de funcionamiento al vacío. Gire la tuerca en el sentido de las manecillas del reloj para disminuir (nivel de vacío más bajo) ambos puntos de funcionamiento. La tuerca de resorte de la gama (A) ajusta los puntos de funcionamiento alto y bajo simultáneamente. La tuerca no cambia el diferencial.

RÉGLAGE**Gamme**

Régler d'abord l'écrou de ressort de la gamme (A) jusqu'à l'obtention du point de fonctionnement sous vide désiré (voir la figure 1). Ce réglage change à la fois les points de fonctionnement haut et bas, mais il faut toujours l'utiliser pour régler le point le plus haut de fonctionnement sous vide. Faire tourner l'écrou dans le sens horaire pour faire diminuer (niveau de vide plus faible) les deux points de fonctionnement. L'écrou de ressort de la gamme (A) règle simultanément les points de fonctionnement haut et bas. Il ne change pas le différentiel.

Differential

The differential spring nut (B) adjusts the lower vacuum point (see Figure 1), changing the operation range. Turn the nut clockwise to decrease the lower vacuum point.

PARTS

For parts locations see Figure 1. When ordering parts, give Class, Type, and Form of switch. Replacement parts are listed in Table 4.

Diferencial

La tuerca de resorte de diferencial (B) ajusta el punto más bajo de vacío (vea la figura 1) lo cual cambia la gama de funcionamiento. Gire la tuerca en el sentido de las manecillas del reloj para disminuir el punto más bajo de vacío.

PIEZAS DE REPUESTO

Para la ubicación de las piezas vea la figura 1. Cuando solicite las piezas, proporcione la clase, el tipo y la forma del interruptor. Las piezas de repuesto se listan en la tabla 4.

Différentiel

L'écrou de ressort de différentiel (B) règle le point de vide le plus bas (voir la figure 1), ce qui change la gamme de fonctionnement. Faire tourner l'écrou dans le sens horaire pour faire diminuer le point de vide le plus faible.

PIÈCES DE RECHANGE

Pour les emplacements des pièces, voir la figure 1. Lors de la commande des pièces, fournir la classe, le type et la forme de l'interrupteur. Les pièces de rechange sont indiquées dans le tableau 4.

Table / Tabla / Tableau 4 : Replacement Parts / Piezas de repuesto / Pièces de rechange

Item Art. Art.	Description Descripción Description	Qty. Cont. Qté.	Part No. No. de pieza N° de pièce	Used on Class 9016 Type G Para uso en la clase 9016 tipo G Utilisée avec la classe 9016 type G		
1	Replacement Contact Kits ^[1] Accesorios de contactos de repuesto ^[1] Kits de contactos de rechange ^[1]	1	9998 PC-207	All except Forms H & R	Todos excepto las formas H y R	Tous sauf les formes H et R
			9998 PC-205	Form R only	Sólo la forma R	Forme R seulement
			9998 PC-206	Form H only	Sólo la forma H	Forme H seulement
2	Diaphragm Assembly ^[2] Ensamble del diafragma ^[2] Assemblage du diaphragme ^[2]	1	9998 PC-210	All types	Todos los tipos	Tous les types
3	Flange Mounting Bracket Kit Accesorio del soporte de montaje sobre bordes Kit de support de montage sur bride	1	9049 A-53	All types	Todos los tipos	Tous les types

^[1] Includes moveable contacts and stationary contact block assembly.
 Incluye los contactos móviles y el ensamble del bloque de contactos fijos.
 Comprend les contacts mobiles et l'assemblage du bloc de contacts stationnaires.

^[2] Order item separately.
 Solicite este artículo por separado.
 Commander l'article séparément.

Square D and  are registered trademarks of Square D Company.

Electrical equipment should be serviced only by qualified electrical maintenance personnel. No responsibility is assumed by Square D for any consequences arising out of the use of this material.

Square D Company
 8001 Highway 64 East
 Knightdale, NC 27545-9023 USA
 (919) 266-3671

Square D y  son marcas registradas de Square D Company.

Solamente el personal de mantenimiento eléctrico especializado deberá prestar servicios de mantenimiento al equipo eléctrico. La Compañía no asume responsabilidad alguna por las consecuencias emergentes de la utilización de este material.

Importado en México por:
 Schneider Electric México, S.A. de C.V.
 Calz. J. Rojo Gómez 1121
 Col. Gpe. del Moral 09300 México, D.F.
 Tel. 686-30-00

Square D et  sont des marques déposées de Square D Company.

L'entretien du matériel électrique ne doit être effectué que par du personnel qualifié. La Société n'assume aucune responsabilité des conséquences éventuelles découlant de l'utilisation de ce matériel.

Schneider Canada Inc.
 19 Waterman Avenue, M4B 1 Y2
 Toronto, Ontario
 (416) 752-8020



WHITE-RODGERS

11A79-2

**Direct Immersion
Hot Water Control
INSTALLATION INSTRUCTIONS**

Operator: Save these instructions for future use!

**FAILURE TO READ AND FOLLOW ALL INSTRUCTIONS CAREFULLY
BEFORE INSTALLING OR OPERATING THIS CONTROL COULD CAUSE
PERSONAL INJURY AND/OR PROPERTY DAMAGE.**

DESCRIPTION

This control is designed for use on hot water heating systems.

It has a coiled element that is immersed directly into the boiler water. This feature gives an unusual speed of response to rapid changes of water temperature thereby preventing thermal lag.

This control has single-pole, double-throw switch action, offering terminals that have open-on-rise switch action as well as close-on-rise switch action. It may be used as a high limit control, low limit control, circulator control, or as a combination low limit and circulator control.

PRECAUTIONS

THIS CONTROL MUST BE INSTALLED BY A QUALIFIED INSTALLER.

Do not exceed the specification ratings.

All wiring must conform to local and national electrical codes and ordinances.

This control is a precision instrument, and should be handled carefully. Rough handling or distorting components could cause the control to malfunction.

This control has been accurately calibrated at the factory. Any attempt to calibrate this control will void the White-Rodgers warranty.

⚠ CAUTION

To prevent electrical shock and/or equipment damage, disconnect electric power to system at main fuse or circuit breaker box until installation is complete.

⚠ CAUTION

Shut off main gas to heating system until installation is complete.

Label all wires prior to disconnection when servicing controls. Wiring errors can cause improper and dangerous operation.

Following installation or replacement, follow appliance manufacturer's recommended installation and/or service instructions to insure proper operation.

⚠ WARNING

Do not use on circuits exceeding specified voltage. Higher voltage will damage control and could cause shock or fire hazard.

INSTALLATION

If the boiler manufacturer recommends a control location, follow such recommendations. If none is offered, the following information gives suggested locations.

For high limit service, the control should be located in the hottest part of the boiler. This is usually at the top of the boiler. A high limit control should **not** be located in the section of the boiler that contains the heat exchanger that supplies domestic hot water.

For low limit or operating service, the control should be located so that it responds to the temperature of the section of the boiler that heats domestic hot water.

When used as a circulator control, it may be located near the boiler outlet or riser.

When used as a combination low limit and circulator control, it should be located the same as suggested for low limit service.

When tightening the control into the boiler, care should be taken to apply all leverage to the hexagonal nut only to avoid damage to the diaphragm or control mechanism.



WHITE-RODGERS DIVISION
EMERSON ELECTRIC CO.
9797 REAVIS ROAD
ST. LOUIS, MISSOURI 63123-5398

Printed in U.S.A.

PART NO. 37-1022B
Replaces 37-1022-A
9520

NOTE

All wiring should be done according to local and national electrical codes.

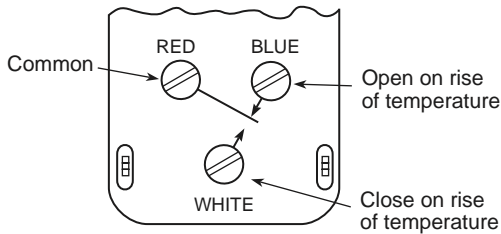

If the boiler or burner manufacturer recommends a wiring diagram, then follow such recommendations. If none are offered, the instruction sheet for the primary control (gas valve or oil burner control) may offer some suggested circuits.

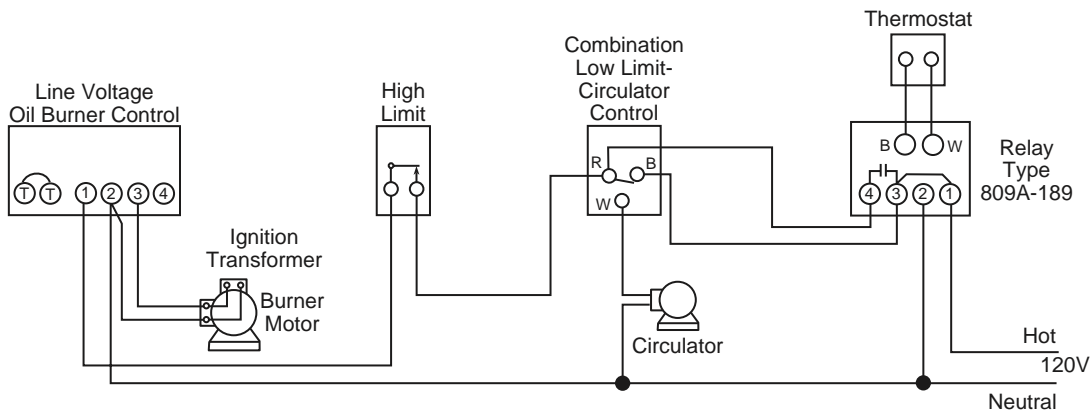

The low limit side of the low limit/circulator control maintains domestic hot water temperature all year around. When the room thermostat calls for heat, the burner and

This control has a single-pole, double-throw snap action switch. The top left-hand terminal (red) is the common terminal. The top right-hand terminal (blue) has open-on-rise switch action. The bottom center terminal (white) has close-on-rise switch action.

Limit Control: When used as either a high limit control or a low limit control, use the open-on-rise terminals (red and blue).

Circulator Control: When used as a circulator control, use the close-on-rise terminals (red and white).

Combination Low Limit and Circulator Control: For this application, all three terminals are used.

The following wiring diagram shows a typical circuit for an oil-fired system with domestic hot water without storage tank.

circulator operate. If boiler water temperature drops too low, the circulator will stop until the temperature rises in boiler.

SETTING THE CONTROL

1. Use a screwdriver in the adjusting slot (A) on the front of the control to turn the dial so the fixed indicator (B) points to the lowest temperature of the cycle.
2. Turn the differential adjusting screw (C) until the movable indicator (D) points to the highest temperature of the cycle.

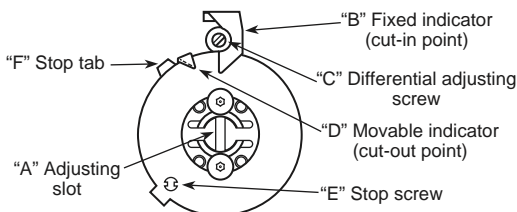

The movable indicator points to the temperature at which the contacts open on **high limit** and **low limit applications**. On **circulator applications**, the movable indicator points to the temperature at which the circulator will start.

On combination low limit and circulator applications, the movable indicator points to the temperature at which the low limit will stop the burner and permit the circulator to run.

CONTROLS WITH ADJUSTABLE STOPS

1. Loosen stop screw (E) with enclosed wrench.
2. Set dial to original equipment manufacturer's specification.
3. Without moving the dial, move stop tab (F) against indicator.
4. Re-tighten stop screw (E).

⚠ CAUTION

Setting stop higher than control being replaced could cause personal injury and/or property damage.



775 Duvick Avenue • Sandwich, IL 60548
Ph: 630.552.3622 • Fax: 630.552.8220
www.fabtekaero.com